

HALL Technical Services, LLC

“The GSE Problem Solvers”

HALL Rear Axle Refurbishment

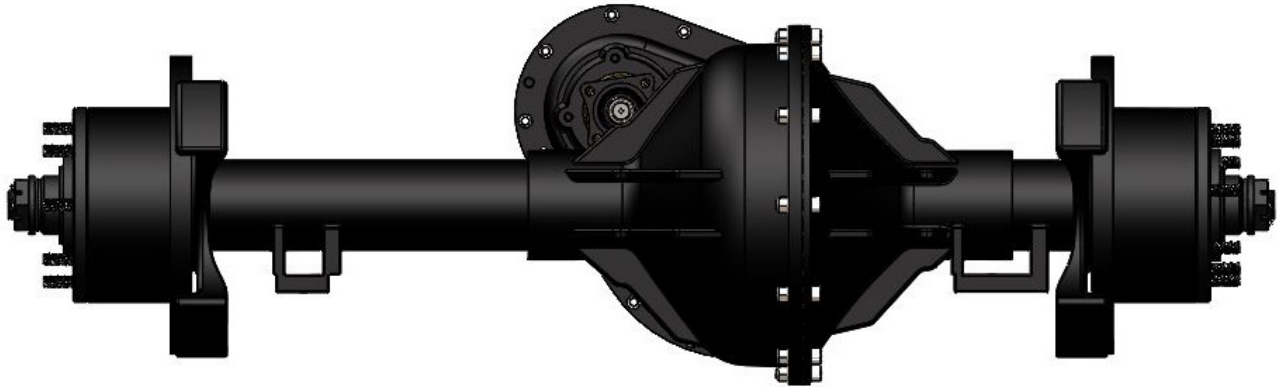

Features

- Each axle meets or exceeds OEM standards
- 1 year warranty
- Axles inspected and completely disassembled
- Non-wear parts measured and inspected for wear and damage
- Axle report and part documents available for each axle
- Parts welded, machined, or replaced as required
- Outer surfaces cleaned and painted using PPG Paints
- Axles are continuously inspected during rebuild to ensure quality
- Axles rebuilt following OEM procedures
- Full final inspection to ensure axles meet or exceed OEM standards
- All bearing cups and cones replaced with USA made bearings
- All gaskets, seals, hardware, and wear components replaced
- Each axle is tested through its operating RPM



Refurbishment

Offered on all series of GSE Baggage Tractor Rear Axles

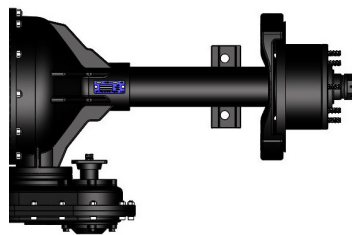

Availability

On the shelf availability for brake and non-brake axles

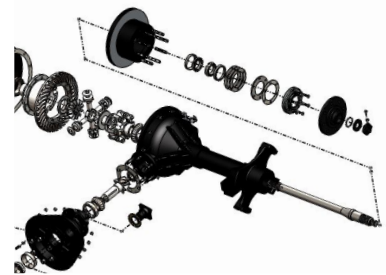

Fast Turn Around

All cores received are rebuilt within 5 business days



Hall Technical Services, LLC
www.halltechservices.com

514 Mecklem Lane
Ellwood City, PA 16117-3028

P: 724.752.2000
F: 724.758.1558