

DATE _____
 CUSTOMER _____
 QUOTE OR JOB NO. _____
 QUANTITY _____
 MATERIAL _____
 HARDNESS _____
 BEARING(S) REQUIRED? _____
 BRONZE BUSHING REQUIRED? _____

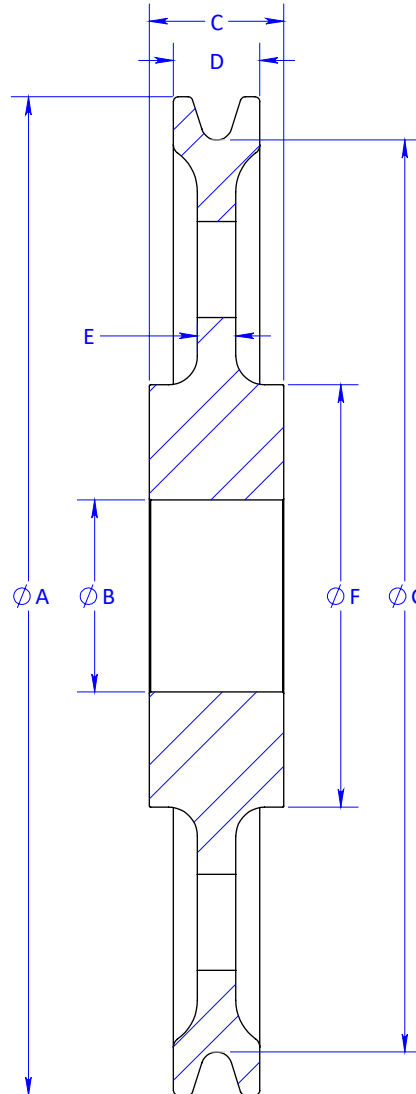

**RECORD AS MANY DIMENSIONS AS POSSIBLE
 MINIMUM A, B, AND C FOR QUOTING PURPOSES**

A	
B	
C	
D	
E	
F	
G	
ROPE DIAMETER	
LIFTING HOLE(S)	



ALSO AVAILABLE...

- GREASE PORT
- GREASE GROOVE IN BORE
- SNAP RING GROOVE(S)
- COUNTERBORES
- HUB HOLES

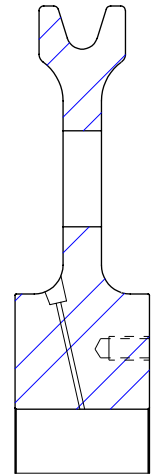

QUESTIONS ?... " Call Hall "
724-752-2000 WHEELS DEPARTMENT
steelwheels@hallindustries.com

© 2017 HALL INDUSTRIES, INC. ALL RIGHTS RESERVED.

HALL INDUSTRIES, INC. PROPRIETARY RIGHTS ARE INCLUDED IN THE INFORMATION DISCLOSED HEREIN. RECIPIENT, BY ACCEPTING THIS DOCUMENT, AGREES THAT NEITHER THIS DOCUMENT NOR THE INFORMATION DISCLOSED HEREIN NOR ANY PART THEREOF SHALL BE REPRODUCED OR TRANSFERRED TO OTHER DOCUMENTS OR USED OR DISCLOSED TO OTHERS FOR MANUFACTURING OR FOR ANY OTHER PURPOSE EXCEPT AS SPECIFICALLY AUTHORIZED IN WRITING BY HALL INDUSTRIES, INC.

hi 514 Mecklem In Ellwood City, PA 16117
Hall Industries, Inc.

CLIENT	SHEAVE BLANK		
FILE NAME	SHEAVE BLANK		
DESCRIPTION	SHEAVE BLANK		
SIZE	DWG/PART NO.	REV	
A	SHEAVE BLANK	0	
SCALE 1:12	WEIGHT: 222.14 LBS	SHEET 1 OF 1	

CHECK	DATE
SHS	10/21/2024
DRAWN	DATE
WGB	10/17/2024

FOLDER - WGB

LAST SAVED: 10/18/2024 PRINTED: 10/18/2024