

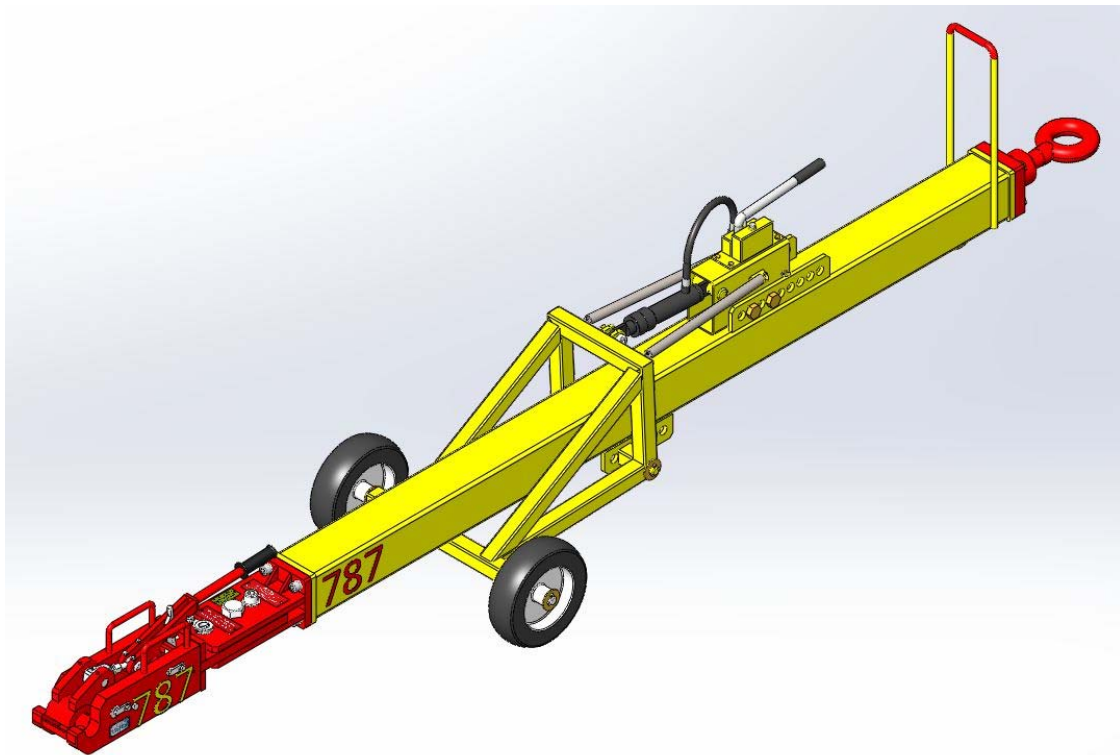

787 TOWBAR

Towbar Specifications, Usage, Preventive Maintenance, and Parts MANUAL



For ordering New Towbars or Replacement Parts Please Contact:

Phone @ 724-752-2000
Or Fax @ 724-758-1558
Or Email @ service@hallindustries.com
Or Online hallindustries.com/manuals

Hall Industries, Inc.
514 Mecklem Lane
Ellwood City, PA 16117
724-752-2000

September 10, 2012
Revision 01



0. Index

Section	Description	Page
One	Specifications	2
Two	Operating Procedures	3
Three	Preventive Maintenance	5
Four	Ordering Info	7
Five	Attachment List	7

1. Specifications

1.1. Physical Specifications

Part Number	Description	Weight	Length
TB-8714-787	Complete 787 Towbar	585 lbs	13'-3"x33"x33"
TB-787-A	Complete Adapter	55 lbs	15"
TB-787-H	Complete Head	75 lbs	21.5"
TB-787-HAC	Complete Adapter & Head	225 lbs	36.5"
TB-787-SP	Shear Pin 787	-	-
TB-8986-1-787	Shear Pin Bushing for Adapter	-	-
TB-8650-29-787	Shear Pin Bushing for Head	-	-
TB-787-PLAQUE	Plaque Shear Pin 787	-	-
TB-787-STICKER-R	Sticker for Bar "787" Red	-	-
TB-787-STICKER-Y	Sticker for Head "787" Yellow	-	-

1.2. Shear Pin Info

Shear Pin	TB-787-SP	Shear Value: 65,000 lbs
-----------	-----------	-------------------------

NOTE: Shear pins are produced in controlled batches; only use Hall Industries replacement shear pins. Shear pin testing and manufacturing records are permanently kept on file for reference.

1.3. Warranty:

All parts are guaranteed against defects for one year. If at any time this manual is not followed it will void the warranty (preventive maintenance logs are required for all warranty replacement parts). All replacement parts must be genuine Hall Industries parts.



2. Operating Procedures

NOTE: This must be done in accordance with the aircraft manual.

2.1. Inspect the Towbar (Prior to hooking up the towbar to the tug visually inspect):

- 2.1.1. Check for a bent or damaged frame and for worn or missing parts.
- 2.1.2. Check tires for damage.
- 2.1.3. Check that you have the correct towbar.
- 2.1.4. Check the shear pin to see if it is the correct pin for the towbar.

NOTE: DO NOT attempt to tow any aircraft with a damaged or improper towbar.

2.2. Responsibility

Operator of the tug must understand that it is his/her responsibility to move the aircraft safely the entire time that they are connected to the plane.

NOTE: No speeding during push and pull.

2.3. Hooking Up to the Plane ~ Checks:

- 2.3.1. You are using the proper tug and towbar for the size aircraft being moved.
- 2.3.2. The towbar you are using is approximately level between the aircraft and the tug.
- 2.3.3. The eye end of the towbar must move freely on the tug hitch.

2.4. Attach the Towbar to the Aircraft

- 2.4.1. Line up towbar to nose pin of aircraft and slide head over the nose pin.
- 2.4.2. Clamp on the jaw. Due to the over-center arrangement of the clamping mechanism, the jaw should remain closed until the handle is released by the operator. As an added safety precaution, the clamping handle is secured by a spring-loaded latch. The head can only be disengaged through simultaneous operation of the latch and handle.
- 2.4.3. Make sure that the spring loaded latch is engaged and is keeping the handle in the down / locked position.



2.5. Attach the Towbar to the Tow Tractor

- 2.5.1. Close the valve on the tow bar's hydraulic pump. Pump the handle to raise the tow eye to the level of the push back's hitch.
- 2.5.2. Position the push back tractor and install the hitch pin.
- 2.5.3. Open the valve on the hydraulic pump; springs will retract the wheel carriage tires off the ground.
- 2.5.4. Tow or push the aircraft only if the tow bar tires are not touching the ground.

2.6. Push the Aircraft

NOTE: This must be done in accordance with the aircraft manual.

NOTE: If at any time the shear pin yields or breaks, carefully bring the aircraft to a stop. Before pushing or tow can be continued a new shear pin must be inserted. Use only Hall Industries shear pin (Part number TB-787-SP).

Basic Rules:

- 2.6.1. Prior to moving, make sure that the hydraulic steering bypass pin is engaged (if applicable). Also double check that all the tie downs and chocks are removed and aircraft brakes are released.

NOTE: This must be done in accordance with the aircraft manual.

- 2.6.2. Tow/Push Slow; max speed is a brisk walk (Approximately 5 MPH). This will help to minimize the chance of a jack-knife.
- 2.6.3. Do not exceed Aircraft nose wheel angle of towing limits. If not marked or not known, do not exceed 30° from center. Be extra cautious on snow and ice.
- 2.6.4. If you are driving make sure that you have plenty of help; "wing walkers" are helpful.
- 2.6.5. Make sure the operator / driver has direct contact with the pilot at all times while moving the aircraft.



NOTE: Thousand of dollars in damage can occur in a few seconds while towing. It is estimated that 90% of towing damage is due to operator negligence / error. Accidents can be fatal.

2.7. Disconnect the Towbar from the Tug

Pump hydraulic wheel carriage down to support weight of towabar then pull hitch pin on tug and have the tug operator back up slowly.

2.8. Disconnect the Towbar from the Aircraft

Release the spring-loaded latch and lift the tow bar head handle. This will release the tow bar head from the tow pin on the aircraft. Carefully lower the tow bar to the ground using the hydraulic lift, then move push back tractor and towbar clear of the aircraft.

3. Preventive Maintenance

NOTE: Hall Industries recommends using this maintenance procedure monthly (or as required in your airlines maintenance procedure if sooner). Replace worn or damaged parts as needed.

3.1. Check Pivot, Capture, and Shear bolt (Part numbers TB-8849-3, TB-8986-7, TB-787-SP); they should be snug but not tight. They should not spin freely, but should be able to spin with the aid of a wrench. Over-tightening will clamp the adapter to the head, and the shear pin will not provide adequate safety protection. With the shear bolt removed, the head must be able to slide within the adapter plates.

NOTE: Do not over-tighten adapter bolts.

3.2. Check wheels and wheel carriage for bent, broken, or worn parts and security. Lubricate pivot points using Hall dry lubricant (Part number TB-LUBE). Check for proper tire pressure, 30 psi. Lubricate wheels.

3.3. Check head assembly for operation of lock mechanism; look for bending, security, etc. Lubricate pivot points using Hall dry lubricant (Part number TB-LUBE) or if joint has a fitting; grease.

3.4. Inspect jaw assembly for worn or damaged parts and security.



3.5. Check head jaw latch adjustment. The closing force on the handle set at the factory is 30-40#. We recommend checking this value monthly. Insert the Test Pin (Hall P/N SS-8114) in the jaws, and measure the force to close the jaws. Should the force be different from that given, the simple adjusting of the turnbuckle is sufficient to reset it. Usually less than 1/8 of a turn of the adjustment nut is sufficient to reset the closing force. Once the jaw is closed it should allow the Test Pin (Hall P/N SS-8114) to rotate between the closed jaws when turned by hand. The slippage can be set by altering the length of the bolts located on both sides of the handle. The adjuster bolts must then be secured by tightening the nuts.

3.6. Check tow eye and hardware (tug attachment) for condition and security.

3.7. Check main body tube for bending or cracking.

3.8. Check shear pin and bushings for breakage, wear and security.

NOTE: If bushings are to be replaced, replace them as a set. Never replace only one bushing.

3.9. Clean, repaint or touch-up paint as required.

3.10. Inspect tags and labels if damaged or missing replace (see the drawings in the attachment section for labels and placements).

3.11. If the towbar is equipped with a hydraulic lift, check the fluid reservoir (in the down / collapsed position). Add fluid if necessary (Part number TB-LUBE-L). Check operation of lift.



4. Ordering Info

- 4.1. Accepted Payments Include (but not limited to):
 - 4.1.1. Visa
 - 4.1.2. MasterCard
 - 4.1.3. American Express
 - 4.1.4. Company Check Wire Transfer
- 4.2. Standard terms ~ NET 30 with approved credit
- 4.3. Minimum Orders ~ \$50
- 4.4. The Order Form is listed in the attachments of this document.

5. Attachment List

- 5.1. TB-8714-787 Complete Towbar Assembly
- 5.2. TB-787-HAC Head and Adapter Complete
- 5.3. TB-8714 Towbar Tube and Wheelset Complete
- 5.4. TB-8714-800 Swivel Eye Complete
- 5.5. Order Form
- 5.6. Other Products and Custom Design Services

NOTES:

1. FOR MORE INFORMATION SEE SUB-ASSEMBLY DRAWINGS.
2. TAGS MUST BE INSTALLED.

REVISIONS				
REV	DESCRIPTION	DATE	BY	CHK

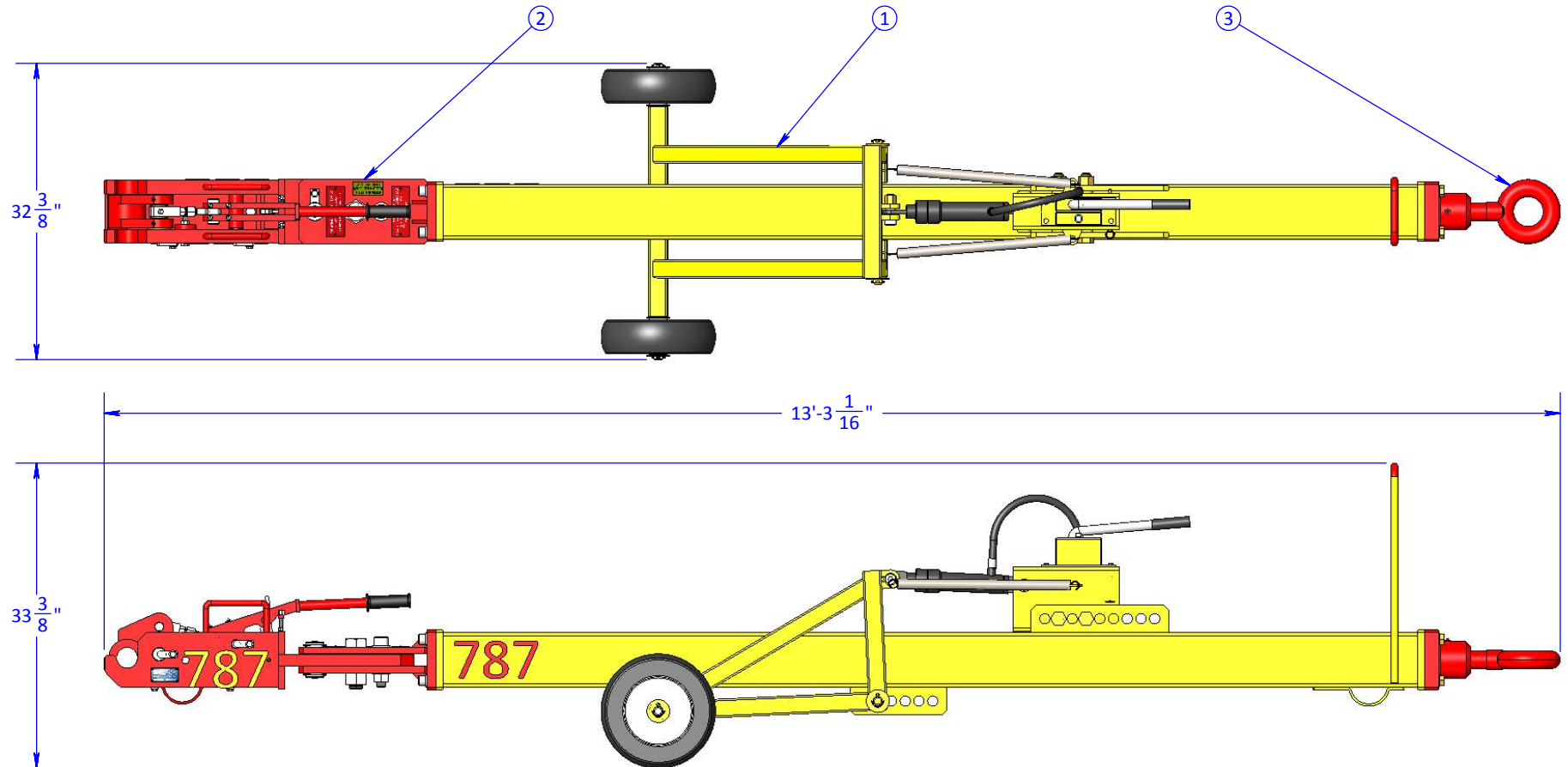

ITEM	QTY	PART NUMBER	DESCRIPTION
1	1	TB-8714	COMPLETE LESS HEAD
2	1	TB-787-HAC	HEAD AND ADAPTER COMPLETE
3	1	TB-8714-800	SWIVEL EYE ASSEMBLY

UNLESS OTHERWISE SPECIFIED DIMENSIONS ARE IN INCHES		514 Mecklem In Ellwood City, PA 16117	
TOLERANCES		hi Hall Industries, Inc.	
ANGLE	.XX .XXX	PROJECT	AV
± 0.5°	± .01 ± .005	FILE NAME	TB-8714-787 TOWBAR COMPLETE
THIRD ANGLE PROJECTION		DESCRIPTION	TOWBAR COMPLETE
PROJECT ID	TM	SIZE	DWG/PART NO.
CHECK	DATE	A	TB-8714-787
DC	9/5/2012	SCALE	1:18
DRAWN	DATE	WEIGHT	584.66 LBS
BJE	9/5/2012	SHEET	1 OF 1
REV	0		

© 2010 HALL INDUSTRIES, INC. ALL RIGHTS RESERVED.

HALL INDUSTRIES, INC. PROPRIETARY RIGHTS ARE INCLUDED IN THE INFORMATION DISCLOSED HEREIN. RECIPIENT, BY ACCEPTING THIS DOCUMENT, AGREES THAT NEITHER THIS DOCUMENT NOR THE INFORMATION DISCLOSED HEREIN NOR ANY PART THEREOF SHALL BE REPRODUCED OR TRANSFERRED TO OTHER DOCUMENTS OR USED OR DISCLOSED TO OTHERS FOR MANUFACTURING OR FOR ANY OTHER PURPOSE EXCEPT AS SPECIFICALLY AUTHORIZED IN WRITING BY HALL INDUSTRIES, INC.

ITEM	QTY.	PART NUMBER	DESCRIPTION
1	1	TB-787-SP	SHEAR PIN 787
2	1	TB-787-PLAQUE	PLAQUE SHEAR PIN 787
3	2	TB-787-STICKERS-Y	STICKER YELLOW
4	1	TB-8312-HA-GRP	GRIP, BLACK
5	1	TB-8312-BA-TAG	YELLOW TORQUE TAG
6	2	TB-8649-23	THRUST BEARING
7	2	TB-8649-24	THRUST BEARING
8	1	TB-8649-14	CLAMP ARM THREADED SHAFT
9	2	TB-8649-21	SET SCREW SQ HEAD 3/8"-16 x 2" SS
10	2	TB-8649-22	NYLOC NUT 3/8"-16 SS
11	2	TB-8649-5	SET SCREW 3/8"-16 x 5/8" LG
12	6	TB-8649-3	HHCS 3/8"-16 x 3/4" LG ZP GR5
13	6	TB-8649-2	GREASE FITTING
14	6	TB-8649-4	LOCK WASHER 3/8"
15	1	TB-8649-6	COMPRESSION SPRING
16	2	TB-8649-1	SET SCREW 1/4"-20 x 1/2" LG
17	1	TB-8649-9	NYLOC NUT 1/2"-13 ZP GR8
18	1	TB-8649-30	NUT 5/8"-11 ZP GR8
19	1	TB-8649-15	ADJUSTABLE CONNECTING ROD
20	1	TB-8649-16	CLAMP CLEVIS
21	1	TB-8649-11	LATCH
22	1	TB-8649-19	FOOT PLATE
23	1	TB-8649-300	ARM ASSEMBLY
24	1	TB-8649-23-1	THRUST BEARING THIN
25	1	TB-8650-60	CLAMP SHAFT WITH KEEPER PLATE
26	1	TB-8650-50	CLAMP SHAFT WITH KEEPER PLATE
27	1	TB-8650-20	JAW STOP
28	1	TB-8650-17	CLEVIS SHAFT
29	1	TB-8650-10	LATCH SHAFT
30	1	TB-8650-8	HHCS 1/2"-13 x 3" ZP GR8
31	1	TB-8650-200	CLAMP
32	1	TB-8650-100	MAIN BODY WELDMENT
33	1	TB-8650-29-787	SHEAR PIN BUSHING
34	1	TB-8849-13	PLAQUE JACK KNIFE
35	1	TB-8849-3	HEAD ADAPTER BOLT
36	10	TB-8849-14	DRIVE RIVET
37	1	TB-8849-4	NUT 1.5"-6 ZP GR8
38	2	TB-8986-9	WASHER 1" SAE HEAVY ZP
39	1	TB-8986-7	SHCS 1"-14 x 4.5" GR8 ZP
40	1	TB-8986-8	NUT 1"-14 GR8 ZP
41	1	TB-8986-6	COTTER PIN
42	2	TB-8986-10	COTTER PIN
43	2	TB-8986-1-787	SHEAR PIN BUSHING ADAPTER
44	2	TB-8986-1KP	ADAPTER KEEPER TAB
45	1	TB-8986-ADPT-WLD	ADAPTER WELDMENT
46	1	TB-TAG-METAL	HALL INDUSTRIES TAG

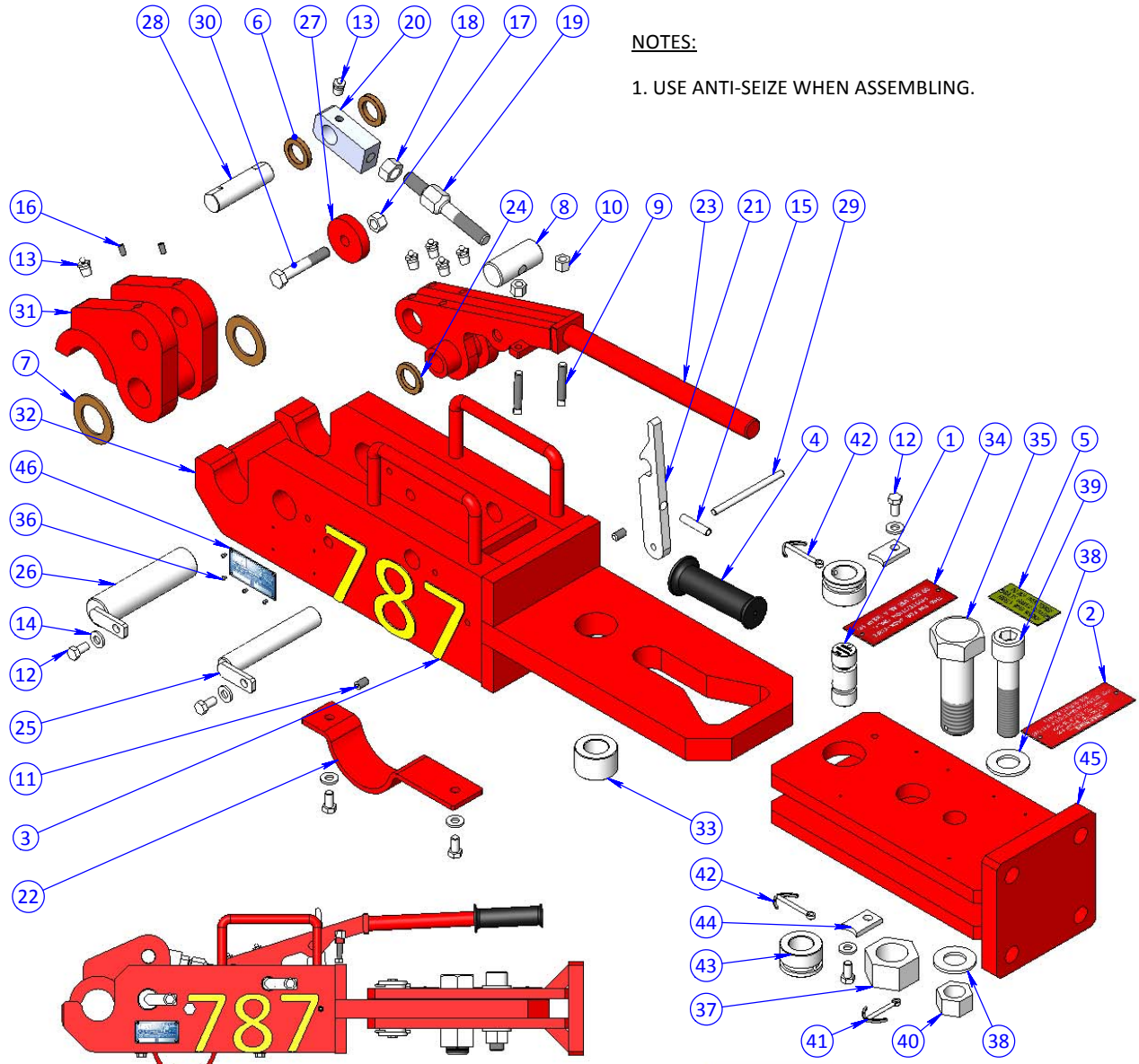

REVISIONS				
REV	DESCRIPTION	DATE	BY	CHK

NOTES:
1. USE ANTI-SEIZE WHEN ASSEMBLING.

UNLESS OTHERWISE SPECIFIED DIMENSIONS ARE IN INCHES		
TOLERANCES		
ANGLE	.XX	.XXX
± 0.5°	± .01	± .005
THIRD ANGLE PROJECTION		
PROJECT ID	TM	
CHECK	DATE	
DC	9/7/2012	
DRAWN	DATE	
BJE	9/4/2012	

		514 Mecklem In Ellwood City, PA 16117	
PROJECT		AV	
FILE NAME		TB-787-HAC HEAD AND ADAPTER COMPLETE	
DESCRIPTION		HEAD AND ADAPTER COMPLETE	
CHECK	DATE	SIZE	DWG/PART NO.
DC	9/7/2012	A	TB-787-HAC
DRAWN	DATE	SCALE	WEIGHT
BJE	9/4/2012	1:8	235.24 LBS
			SHEET 1 OF 1

© 2010 HALL INDUSTRIES, INC. ALL RIGHTS RESERVED.

NOTES:

1. LANYARD FOR LIFT BOX PIN NOT SHOWN.

REVISIONS				
REV	DESCRIPTION	DATE	BY	CHK

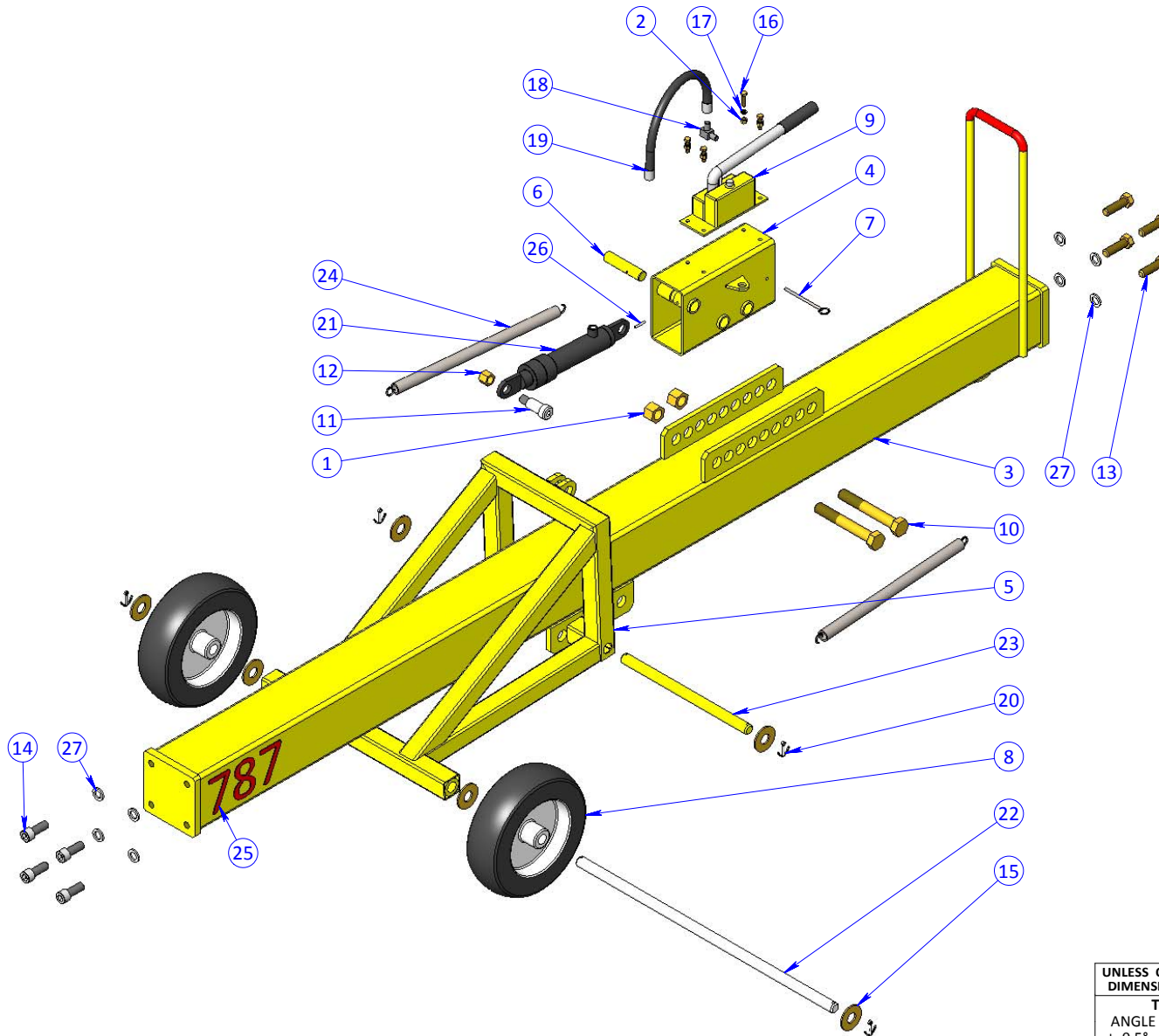

ITEM	QTY.	PART NUMBER	DESCRIPTION
1	2	TB-8714-21-N	NYLOC NUT 1"-8
2	4	TB-8714-25-N	NYLOC NUT 5/16"-18
3	1	TB-8714-100	MAIN TOWBAR WELDMENT
4	1	TB-8714-400	HYD PLATFORM AND BOX
5	1	TB-8714-200	WHEEL FRAME WELDMENT
6	1	TB-8714-400-A3	PIN
7	1	TB-8714-400-C	LIFT BOX PIN
8	2	TB-8714-40	WHEEL
9	1	TB-8714-24	HYD HAND PUMP
10	2	TB-8714-21	HH BOLT 1"-8 x 7"
11	1	TB-8714-29	SHOULDER BOLT 1" x 1.75"
12	1	TB-8714-31	NYLOC NUT 3/4"-10
13	4	TB-8714-11	HH BOLT 3/4"-10 x 2.5"
14	4	TB-8714-12	SHCS 3/4"-10 x 2"
15	6	TB-8714-35	FLAT WASHER 1"
16	4	TB-8714-25	HH BOLT 5/16"-18 x 1.25"
17	4	TB-8714-2	LOCK WASHER 5/16"
18	1	TB-8714-43	ELBOW HYD
19	1	TB-8714-23	HOSE HYD
20	4	TB-8714-28	COTTER PIN
21	1	TB-8714-20	LIFT CYLINDER
22	1	TB-8714-33	LONG AXLE
23	1	TB-8714-32	LOWER SHAFT
24	2	TB-8714-10	PLATED SPRING
25	2	TB-787-STICKER-R	STICKER RED
26	1	P44320048BX0000	SPRING PIN
27	8	NL 3/4"	LOCK WASHER

© 2010 HALL INDUSTRIES, INC. ALL RIGHTS RESERVED.

HALL INDUSTRIES, INC. PROPRIETARY RIGHTS ARE INCLUDED IN THE INFORMATION DISCLOSED HEREIN. RECIPIENT, BY ACCEPTING THIS DOCUMENT, AGREES THAT NEITHER THIS DOCUMENT NOR THE INFORMATION DISCLOSED HEREIN NOR ANY PART THEREOF SHALL BE REPRODUCED OR TRANSFERRED TO OTHER DOCUMENTS OR USED OR DISCLOSED TO OTHERS FOR MANUFACTURING OR FOR ANY OTHER PURPOSE EXCEPT AS SPECIFICALLY AUTHORIZED IN WRITING BY HALL INDUSTRIES, INC.

UNLESS OTHERWISE SPECIFIED DIMENSIONS ARE IN INCHES

TOLERANCES		
ANGLE	.XX	.XXX
± 0.5°	± .01	± .005

THIRD ANGLE PROJECTION

PROJECT ID AV1103

CHECK DC	DATE 8/31/2012
DRAWN BJE	DATE 8/31/2012

hi 514 Mecklem In Ellwood City, PA 16117
Hall Industries, Inc.

PROJECT	AV
FILE NAME	TB-8714 TOWBAR COMPLETE LESS HEAD
DESCRIPTION	COMPLETE LESS HEAD
SIZE	DWG/PART NO.
A	TB-8714
SCALE 1:15	WEIGHT: 306.35 LBS
SHEET 1 OF 1	

REV 0

NOTES:

1. USE NEVERSIEZE WHEN PUTTING ASSEMBLY TOGETHER.
2. USE TAPE TO HOLD BRONZE SPACER ON THE END OF THE ASSEMBLY.

REVISIONS				
REV	DESCRIPTION	DATE	BY	CHK
0	ORIGINAL	8/9/1996	KK	-
1	UPDATE	5/3/2011	BJE	DC

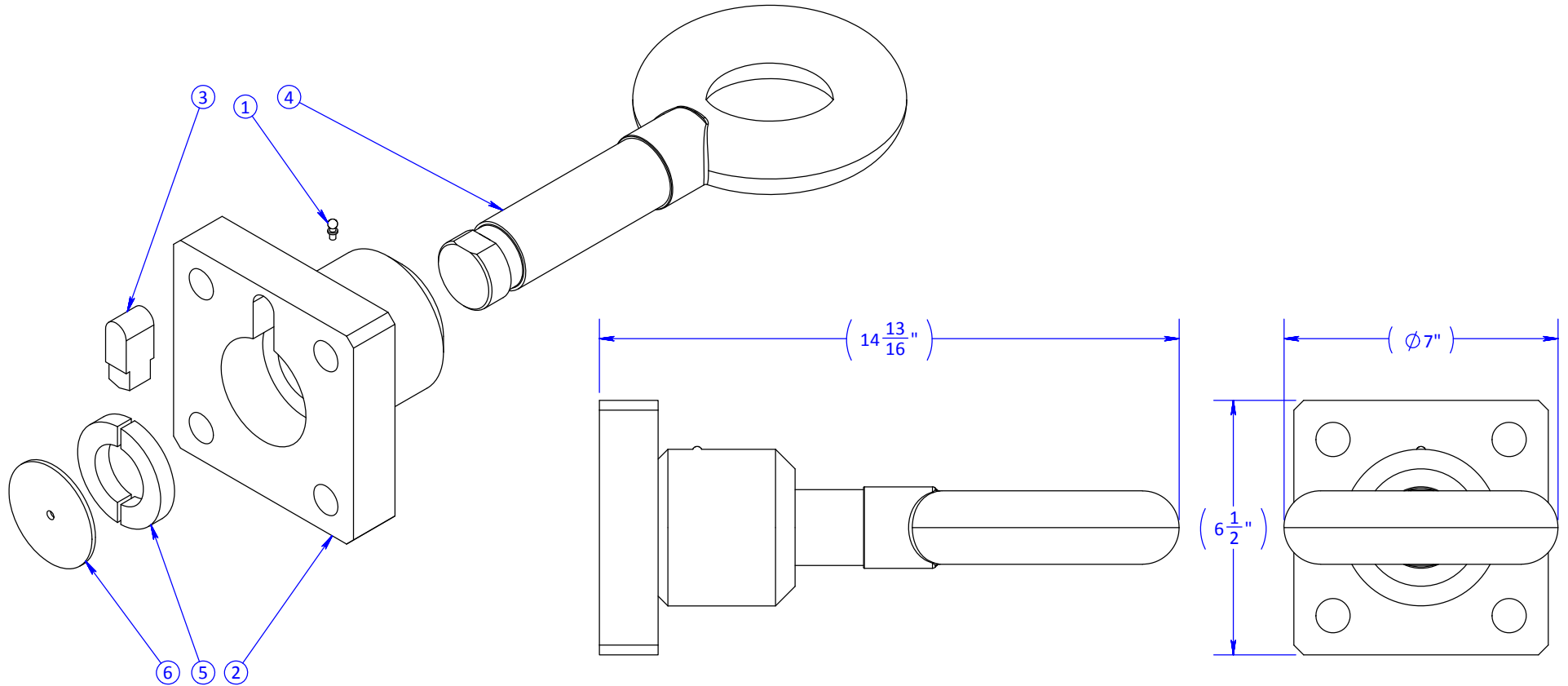

ITEM	QTY.	PART NUMBER	DESCRIPTION
1	1	TB-8649-2	GREASE FITTING
2	1	TB-8714-800-WLD	HUB WELDMENT
3	1	TB-8714-802K	SWIVEL KEY
4	1	TB-8714-810	EYE SWIVEL
5	2	TB-8714-811	SPLIT COLLAR RETAINING RING
6	1	TB-8714-812	BRONZE THRUST DISK

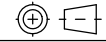
UNLESS OTHERWISE SPECIFIED DIMENSIONS ARE IN INCHES		 514 Mecklem In Ellwood City, PA 16117 Hall Industries, Inc.	
TOLERANCES		PROJECT	AV
ANGLE .XX .XXX ± 0.5° ± .01 ± .005		FILE NAME	TB-8714-800 SWIVEL EYE ASSEMBLY
THIRD ANGLE PROJECTION 		DESCRIPTION	SWIVEL EYE ASSEMBLY
PROJECT ID AV1103		SIZE DWG/PART NO.	A TB-8714-800
CHECK DC	DATE 5/3/2011	SCALE 1:4	WEIGHT: 43.04 LBS
DRAWN BJE	DATE 5/3/2011		SHEET 1 OF 1
			REV 1

© 2010 HALL INDUSTRIES, INC. ALL RIGHTS RESERVED.

HALL INDUSTRIES, INC. PROPRIETARY RIGHTS ARE INCLUDED IN THE INFORMATION DISCLOSED HEREIN. RECIPIENT, BY ACCEPTING THIS DOCUMENT, AGREES THAT NEITHER THIS DOCUMENT NOR THE INFORMATION DISCLOSED HEREIN NOR ANY PART THEREOF SHALL BE REPRODUCED OR TRANSFERRED TO OTHER DOCUMENTS OR USED OR DISCLOSED TO OTHERS FOR MANUFACTURING OR FOR ANY OTHER PURPOSE EXCEPT AS SPECIFICALLY AUTHORIZED IN WRITING BY HALL INDUSTRIES, INC.

Hall Industries Equipment Division ~ AIRLINE ORDERS

FAX#: 724 758-1558 PHONE # : 724 752-2000

ORDER DATE: _____ TAKEN BY: _____ TIME: _____ AIRLINE CODE: _____
 PERSON CALLING: _____ PHONE#: _____ FAX: _____
 E-MAIL ADDRESS: _____ CUSTOMER P.O.# _____
 MASTER CARD# _____
 EXP. DATE: _____ CVC# _____
 SHIP DATE: _____ HOW TO SHIP: UPS: GRD _____ RED _____ OTHER _____
 FED EX: GRD _____ O/N _____ O/N P1 _____ OTHER _____ Acct. # _____
 TRUCKING COMPANY: _____
 HUB : _____ EMPLOYEE # _____
 BILLING ADDRESS: _____ SHIP TO ADDRESS: _____

PART NUMBER:	DESCRIPTION:	QTY:	PRICE:

NOTES: _____

Other Products and Custom Design Services:

Hall Industries provides a number of additional products beyond our towbar line. Some of the custom projects that we have done are shown below. We have our own engineering staff along with machine, fabrication, and GSE maintenance shops. We can design and build your ideas to increase safety, productivity, and profits.



0017-0001 Custom Towbar (Solve a Problem)

<<This project involved designing and manufacturing a custom towbar to be used in the Nuclear Industry. This towbar shipped complete with custom shear pins calibrated to the application.



IA-8980 Preconditioned Air Inlet (PCA) Adapters

<< Our PCA Inlet Adapters are part of our GSE product line. We inventory all of the parts and can ship usually the same day as ordered.>>



0010-0001 Certified Transmission Lifting Bracket (Meet a Demand)

A customer came to us with a lifting problem. They needed a tested and certified lifting bracket to prevent them from getting cited by OSHA. We designed, tested, and fabricated a solution. >>



<<1000-3002 Adapter 8312 to Tronair 1000-0001 Hydro Adapter Assembly>>

Hall Industries offers adapters for nearly every towbar (even competitors) that allow you to use our towbar tubes / heads with your existing equipment.



Besides the products listed above some of the other things that we sell include PCA ducting, Solid PBB tires, and baggage cart tires.

Feel free to contact us about your GSE problems; after all we are "The Problem Solvers".