



CRJ-100/200 TOWBAR

Towbar Specifications, Usage, Preventive Maintenance, and Parts

MANUAL

(Includes Optional Hydraulic Lift and Soft Start)



For ordering New Towbars or Replacement Parts Please Contact:

Towbar Parts @ 724-752-2000
Or Fax @ 724-758-1558
Or Email @ service@hallindustries.com

Hall Industries, Inc.
514 Mecklem Lane
Ellwood City, PA 16117
724-752-2000

August 5, 2013
Revision 01



08-05-13 REV01 Update Manual

0. Index

Section	Description	Page
One	Specifications	2
Two	Operating Procedures	3
Three	Preventive Maintenance	4
Four	Replacement Part Kits / Assemblies	5
Five	Ordering Info	5
Six	How to find the part you need	6
Seven	Attachment List	6

1. Specifications

1.1. Physical Specifications

Part Number	Description	Weight	Length
CRJ-100	Full Assembly (25" Height x 35" Wide) With Fixed Wheel Carriage & Standard Eye	210 lb	12' 10"
CRJ-100-HL-SS	Full Assembly (30" Height x 20" Wide) With Hydraulic Lift Wheel Carriage & Soft Start	235lb	12' 10"
CRJ-100-SS	Full Assembly (30" Height x 20" Wide) With Fixed Wheel Carriage & Soft Start	225 lb	12' 10"
CRJ-100-HL	Full Assembly (30" Height x 20" Wide) With Hydraulic Lift Wheel Carriage	225 lb	12' 10"
CRJ-100-5	Towbar Head	78 lb	35"

1.2. Warranty:

All parts are guaranteed against defects for one year. If at any time this manual is not followed it will void the warranty (preventive maintenance logs are required for all warranty replacement parts). All replacement parts must be genuine Hall Industries parts.

1.3. Updates:

Our manuals are updated periodically please check for updates on our website prior to ordering.



2. Operating Procedures

NOTE: This must be done in accordance with the aircraft manual.

2.1. Inspect the Towbar (Prior to hooking up the towbar to the tug visually inspect):

- 2.1.1. Check for a bent or damaged frame and for worn or missing parts.
- 2.1.2. Check tires for damage.
- 2.1.3. Check that you have the proper towbar.

NOTE: DO NOT attempt to tow any aircraft with a damaged or improper towbar.

2.2. Responsibility

Operator of the tug must understand that it is his/her responsibility to move the aircraft safely the entire time that they are connected to the plane.

NOTE: No speeding during push and pull.

2.3. Hooking Up to the Plane ~ Checks:

- 2.3.1. You are using the proper tug and towbar for the size aircraft being moved.
- 2.3.2. The towbar you are using is approximately level between the aircraft and the tug.
- 2.3.3. The eye end of the towbar must move freely on the hitch mounted on the tug.

2.4. Attach the Towbar to the Aircraft

- 2.4.1. First check that the towbar head pins are in the open position.
- 2.4.2. Line up towbar to nose pin of aircraft and close nose pins.
- 2.4.3. Install lock pins.

2.5. Attach the Towbar to the Tow Tractor

- 2.5.1. Lift to the level of the push back's hitch.
- 2.5.2. Position the push back tractor and install the hitch pin.
- 2.5.3. Tow or push the aircraft only if the tow bars tires are not touching the ground.

2.6. Push the Aircraft



NOTE: This must be done in accordance with the aircraft manual.

Basic Rules:

2.6.1. Prior to moving, make sure that full swivel release pins are released (if applicable). Also double check that all the tie downs and chocks are removed and aircraft brakes are released.

NOTE: This must be done in accordance with the aircraft manual.

2.6.2. Tow Slow, max speed is a brisk walk (Approximately 5 MPH). This will help to minimize the chance of a jack-knife.

2.6.3. Do not exceed Aircraft nose wheel angle of towing limits. If not marked or not known, do not exceed 30° from center. Be extra cautious on snow and ice.

2.6.4. If you are driving make sure that you have plenty of help; “wing walkers” are helpful.

2.6.5. Make sure the operator / driver has direct contact with the pilot at all times while moving the aircraft.

NOTE: Thousand of dollars in damage can occur in a few seconds while towing. It is estimated that 90% of towing damage is due to operator negligence / error. Accidents can be fatal.

2.7. Disconnect the Towbar from the Tug

2.8. Disconnect the Towbar from the Aircraft

Remove lock pins and slide pins into the open position. Carefully lower the tow bar to the ground (use hydraulic lift if installed), and then move push back tractor and towbar clear of the aircraft.

3. Preventive Maintenance

NOTE: Hall Industries recommends using this maintenance procedure monthly (or as required in your airlines maintenance procedure if sooner). Replace worn or damaged parts as needed.

3.1. Check the head retention pin and the soft start eye retaining bolts for wear.



- 3.2. Check wheels and wheel carriage for bent, broken, or worn parts and security. Lubricate pivot points using Hall lubricant (Part number TB-LUBE).
- 3.3. Check head assembly for operation of latch mechanism; look for bending, security, etc. Lubricate pivot points using Hall lubricant (Part number TB-LUBE).
- 3.4. Inspect jaw assembly for worn or damaged parts and security.
- 3.5. Check latch mechanism to ensure proper travel back and forth. Lubricate pivot points.
- 3.6. Check tow eye and hardware (tug attachment) for condition and security.
- 3.7. Check main body tube for bending or cracking.
- 3.8. Clean, repaint, or touch-up paint as required.
- 3.9. Inspect tags and labels if damaged or missing replace (see the drawings in the attachment section for labels and placements).
- 3.10. If the towbar is equipped with a hydraulic lift, check the fluid reservoir (in the down / collapsed position). Add fluid if necessary (Part number TB-LUBE-L).

4. Replacement Parts, Kits, & Assemblies

Part Number	QTY (in Kit)	Description
4.1. CRJ-100-11-2-KIT	SHEAR PIN KIT	
4.1.1. CRJ-100-11-2	2	Shear Pin
4.1.2. HRJ-145-11-2A	2	Locknut
4.1.3. CRJ-7-1-E	1	Head Bushing
4.1.4. CRJ-700--11-3	2	Adapter Bushing

5. Ordering Info

- 5.1. Accepted Payments Include (but not limited to):
 - 5.1.1. Visa
 - 5.1.2. MasterCard
 - 5.1.3. American Express
 - 5.1.4. Company Check Wire Transfer



- 5.2. Standard terms ~ NET 30 with approved credit
- 5.3. Minimum Orders ~ \$50
- 5.4. The Order Form is listed in the attachments of this document.

6. How to find the part you need

- 6.1. What pushbar do I need?
 - 6.1.1. Soft Start Eyelet or Standard Eyelet (user preference)
- 6.2. What wheel carriage do I need?
 - 6.2.1. Fixed or Hydraulic lift (user preference)

7. Attachment List

- | | |
|---|---|
| 7.1. CRJ-100 | CRJ-100 & 200 Towbar Complete |
| 7.2. CRJ-100-5 | CRJ-100 & 200 Towbar Head Complete |
| 7.3. HRJ-145-12-1-TE-SS | Towbar Tube with Soft Start Toweye Assembly |
| 7.4. TB-SS3.5-D8Q | Repairable Soft Start Assembly |
| 7.5. HRJ-145-12-1-TE | Towbar Tube with Standard Toweye Assembly |
| 7.6. CRJ-400 | Fixed Wheel Carriage |
| 7.7. REG-LIFT | Regional Towbar Lift ~ Hydraulic 3 ½" |
| 7.8. HRJ-145-12-2ASY | Handle Assembly |
| 7.9. AV1009-0002 | Drag Plate 3.5" Bolted |
| 7.10. Soft Start Brochure | |
| 7.11. Order Form | |
| 7.12. Other Products and Custom Design Services | |

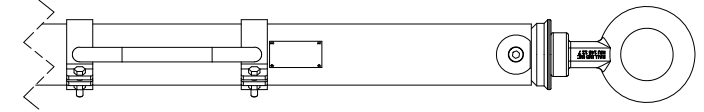
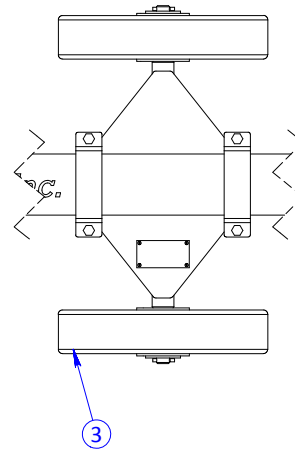
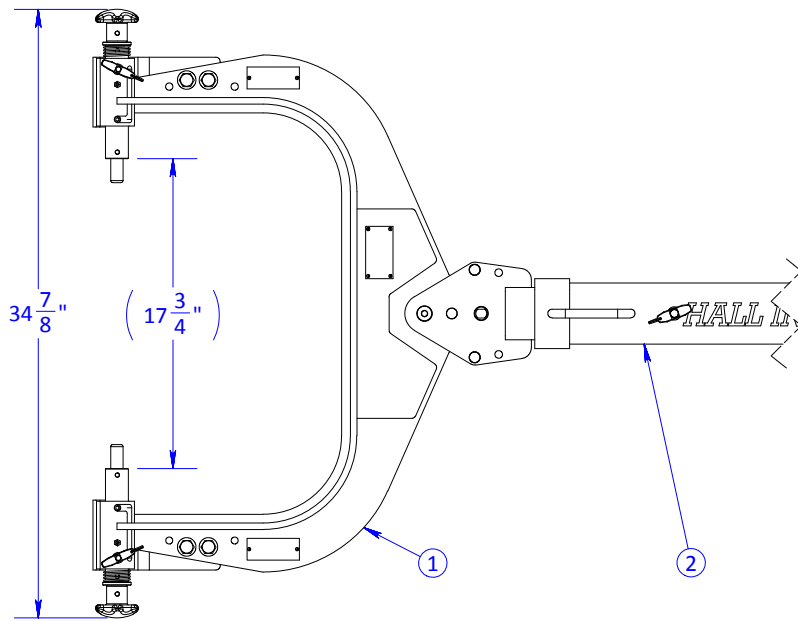

ITEM	QTY	PART NUMBER	DESCRIPTION
1	1	CRJ-100-5	HEAD AND ADAPTER COMPLETE
2	1	HRJ-145-12-1-TE	TOWBAR TUBE AND EYE
3	1	CRJ-400	FIXED WHEEL CARRIAGE
4	1	HRJ-145-12-2ASY	HANDLE ASSEMBLY

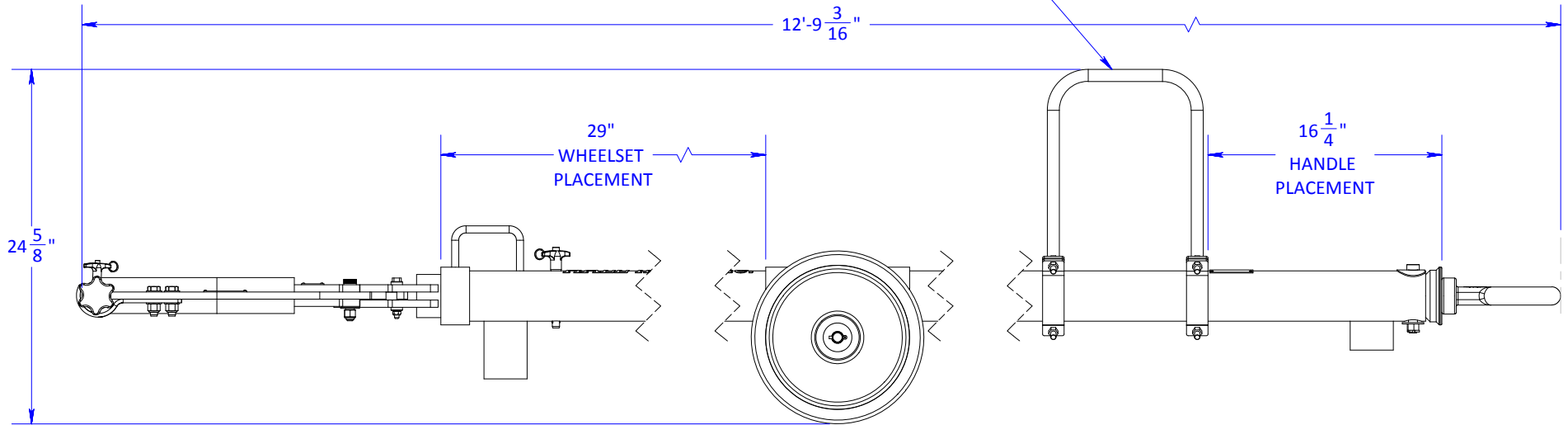

CRJ-100 & 200

CONFIGURATIONS	WITH FIXED WHEELSET	W/ HYDRAULIC WHEELSET
STANDARD EYELET	CRJ-100	CRJ-100-HL
SOFT START EYELET	CRJ-100-SS	CRJ-100-HL-SS

UNLESS OTHERWISE SPECIFIED DIMENSIONS ARE IN INCHES

TOLERANCES		
ANGLE	.XX	.XXX
± 0.5°	± .01	± .005
X<12"=± 1/32"	X>12"=±1/16"	

THIRD ANGLE PROJECTION

CHECK DC	DATE 7/30/2013
DRAWN BJE	DATE 7/30/2013

hi 514 Mecklem In Ellwood City, PA 16117
Hall Industries, Inc.

PROJECT	AV
FILE NAME	CRJ-100 TOWBAR COMPLETE
DESCRIPTION	TOWBAR COMPLETE
SIZE	DWG/PART NO.
A	CRJ-100
SCALE 1:11	WEIGHT: 208.21 LBS
SHEET 1 OF 1	

© 2013 HALL INDUSTRIES, INC. ALL RIGHTS RESERVED.

HALL INDUSTRIES, INC. PROPRIETARY RIGHTS ARE INCLUDED IN THE INFORMATION DISCLOSED HEREIN. RECIPIENT, BY ACCEPTING THIS DOCUMENT, AGREES THAT NEITHER THIS DOCUMENT NOR THE INFORMATION DISCLOSED HEREIN NOR ANY PART THEREOF SHALL BE REPRODUCED OR TRANSFERRED TO OTHER DOCUMENTS OR USED OR DISCLOSED TO OTHERS FOR MANUFACTURING OR FOR ANY OTHER PURPOSE EXCEPT AS SPECIFICALLY AUTHORIZED IN WRITING BY HALL INDUSTRIES, INC.

NOTES:

1.

REVISIONS				
REV	DESCRIPTION	DATE	BY	CHK

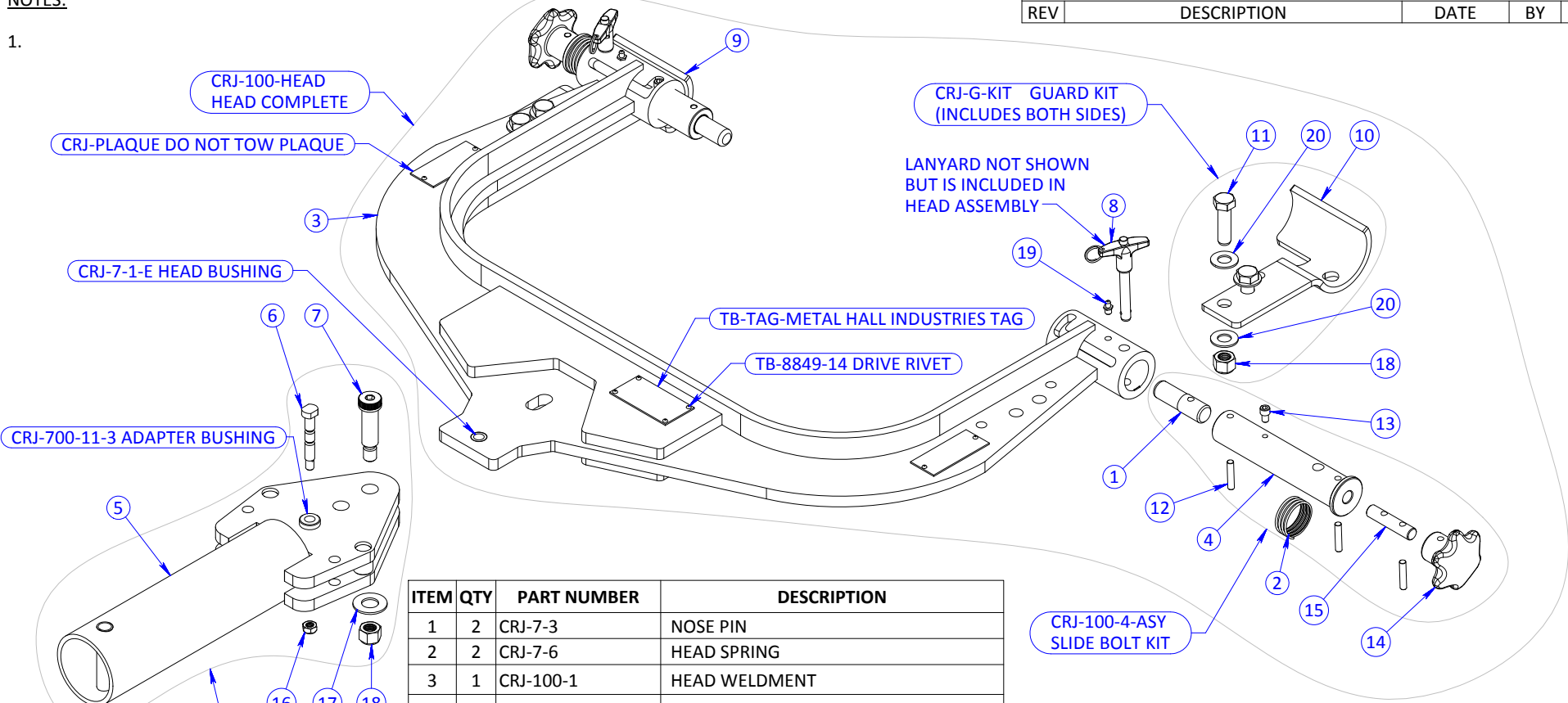

ITEM	QTY	PART NUMBER	DESCRIPTION
1	2	CRJ-7-3	NOSE PIN
2	2	CRJ-7-6	HEAD SPRING
3	1	CRJ-100-1	HEAD WELDMENT
4	2	CRJ-100-4	SLIDE BOLT
5	1	CRJ-100-11-1	ADAPTER WELDMENT
6	1	CRJ-100-11-2	SHEAR PIN
7	1	CRJ-100-11-4	SHOULDER BOLT
8	2	CRJ-700-QRP	QUICK RELEASE PIN
9	1	CRJ-G-L	CRJ GUARD, LEFT
10	1	CRJ-G-R	CRJ GUARD, RIGHT
11	4	H508C0056ZP0000	HH BOLT 1/2"-13 x 1.75" LONG YZP GR.5
12	6	HRJ-145-7-2	ROLL PIN
13	2	HRJ-145-7-5	RETAINER SCREW
14	2	HRJ-145-7-8	ALUMINUM KNOB
15	2	HRJ-145-7-9	HANDLE-SLIDE BOLT PIN
16	1	HRJ-145-11-2A	STOVER LOCKNUT
17	1	HRJ-145-11-5	WASHER FLAT 5/8" ZP SAE
18	5	TB-8312-H7	NYLOC NUT 1/2"-13
19	2	TB-9205-11A-MKM	GREASE FITTING
20	8	WH4520000ZP0000	WASHER 1/2" SAE YZP

CRJ-100 & 200

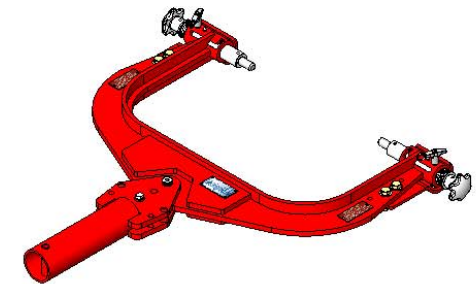

© 2013 HALL INDUSTRIES, INC. ALL RIGHTS RESERVED.

HALL INDUSTRIES, INC. PROPRIETARY RIGHTS ARE INCLUDED IN THE INFORMATION DISCLOSED HEREIN. RECIPIENT, BY ACCEPTING THIS DOCUMENT, AGREES THAT NEITHER THIS DOCUMENT NOR THE INFORMATION DISCLOSED HEREIN NOR ANY PART THEREOF SHALL BE REPRODUCED OR TRANSFERRED TO OTHER DOCUMENTS OR USED OR DISCLOSED TO OTHERS FOR MANUFACTURING OR FOR ANY OTHER PURPOSE EXCEPT AS SPECIFICALLY AUTHORIZED IN WRITING BY HALL INDUSTRIES, INC.

UNLESS OTHERWISE SPECIFIED DIMENSIONS ARE IN INCHES		hi 514 Mecklem In Ellwood City, PA 16117	
TOLERANCES		Hall Industries, Inc.	
ANGLE .XX .XXX	± 0.5° ± .01 ± .005	PROJECT	AV
X<12"=± 1/32" X>12"=±1/16"		FILE NAME	CRJ-100-5 HEAD AND ADAPTER COMPLETE
THIRD ANGLE PROJECTION		DESCRIPTION	HEAD AND ADAPTER COMPLETE
CHECK DC	DATE 7/26/2013	SIZE	DWG/PART NO. CRJ-100-5
DRAWN BJE	DATE 7/25/2013	SCALE	1:6
		WEIGHT	77.89 LBS
		SHEET	1 OF 1
		REV	0

NOTES:

1. ANTI-SIEZE ALL THREADS & WIRE TIE BOLTS.
2. TAGS MUST BE INSTALLED.

REVISIONS				
REV	DESCRIPTION	DATE	BY	CHK
1	ADD DECAL	8/5/2013	BJE	DC

REPAIRABLE SOFT START

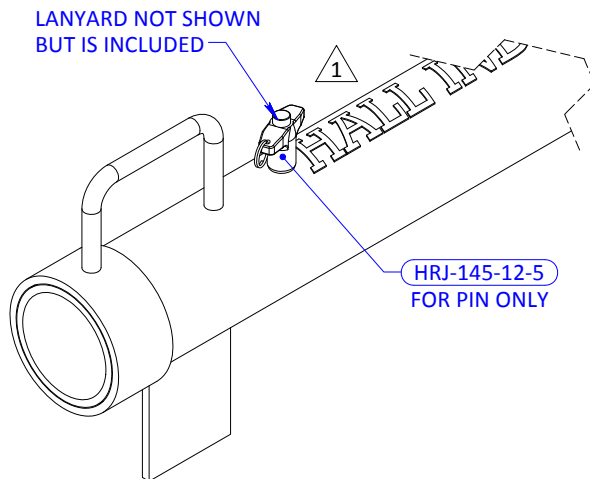
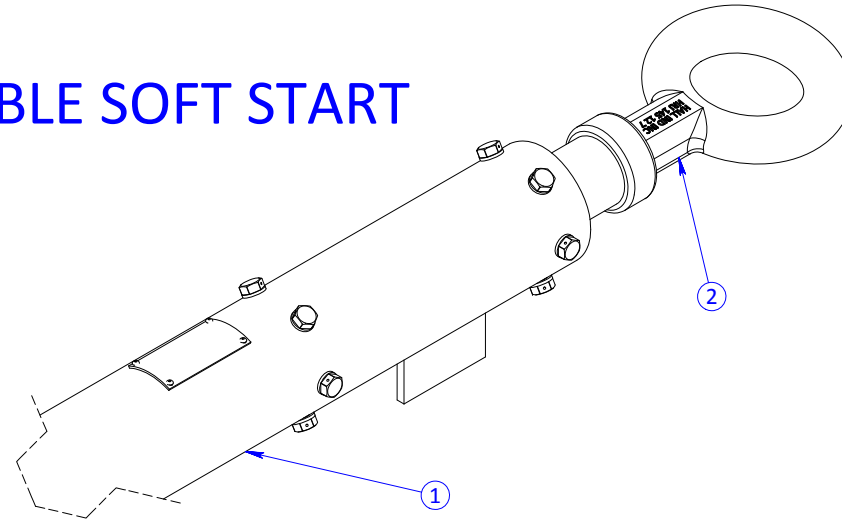

ITEM	QTY.	PART NUMBER	DESCRIPTION
1	1	HRJ-145-12-1-SS	3.5" TUBE WITH TAG AND DECAL
2	1	TB-SS3.5-D8Q	SOFT START 3.5 INCH

UNLESS OTHERWISE SPECIFIED
DIMENSIONS ARE IN INCHES

TOLERANCES		
ANGLE	.XX	.XXX
± 0.5°	± .01	± .005
X<12"=± 1/32"	X>12"=±1/16"	

THIRD ANGLE PROJECTION

CHECK VTM	DATE 6/29/2013
DRAWN BJE	DATE 6/29/2013

514 Mecklem In Ellwood City, PA 16117
Hall Industries, Inc.

PROJECT	AV
FILE NAME	HRJ-145-12-1-TE-SS TUBE AND SOFT START TOWEYE
DESCRIPTION	TUBE AND SOFT START TOWEYE
SIZE	DWG/PART NO.
A	HRJ-145-12-1-TE-SS
SCALE 1:5	WEIGHT: 103.25 LBS
SHEET 1 OF 1	

© 2013 HALL INDUSTRIES, INC. ALL RIGHTS RESERVED.

HALL INDUSTRIES, INC. PROPRIETARY RIGHTS ARE INCLUDED IN THE INFORMATION DISCLOSED HEREIN. RECIPIENT, BY ACCEPTING THIS DOCUMENT, AGREES THAT NEITHER THIS DOCUMENT NOR THE INFORMATION DISCLOSED HEREIN NOR ANY PART THEREOF SHALL BE REPRODUCED OR TRANSFERRED TO OTHER DOCUMENTS OR USED OR DISCLOSED TO OTHERS FOR MANUFACTURING OR FOR ANY OTHER PURPOSE EXCEPT AS SPECIFICALLY AUTHORIZED IN WRITING BY HALL INDUSTRIES, INC.

NOTES:

1. USE ANTI-SEIZE ON ALL THREADED HARDWARE.

REVISIONS				
REV	DESCRIPTION	DATE	BY	CHK

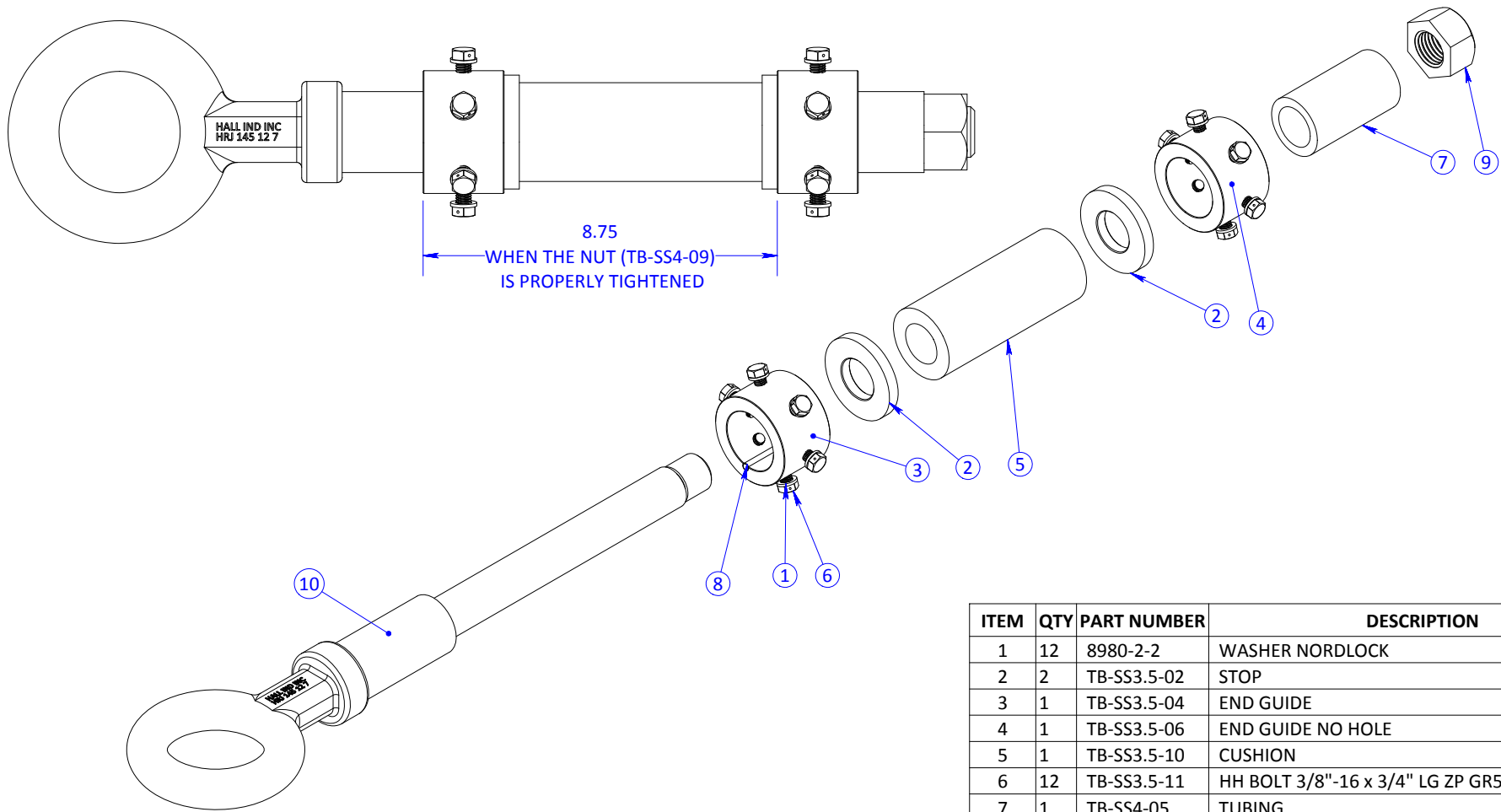

ITEM	QTY	PART NUMBER	DESCRIPTION
1	12	8980-2-2	WASHER NORDLOCK
2	2	TB-SS3.5-02	STOP
3	1	TB-SS3.5-04	END GUIDE
4	1	TB-SS3.5-06	END GUIDE NO HOLE
5	1	TB-SS3.5-10	CUSHION
6	12	TB-SS3.5-11	HH BOLT 3/8"-16 x 3/4" LG ZP GR5 DRILLED HEAD
7	1	TB-SS4-05	TUBING
8	1	TB-SS4-07	DOWEL PIN 1/4" DIA. x 2" LONG SS
9	1	TB-SS4-09	NUT 1-1/4"-7 THREAD GR5 ZP
10	1	TB-SS4-11	EYE & SHAFT

UNLESS OTHERWISE SPECIFIED DIMENSIONS ARE IN INCHES

TOLERANCES		
ANGLE	.XX	.XXX
± 0.5°	± .01	± .005
X<12"=± 1/32"	X>12"=±1/16"	

THIRD ANGLE PROJECTION

CHECK VTM	DATE 6/29/2013
DRAWN BJE	DATE 06/29/2013

hi 514 Mecklem In Ellwood City, PA 16117
Hall Industries, Inc.

PROJECT	AV ~ SS EYE D8Q, HRJ
FOLDER / FILE NAME	AV0801/ TB-SS3.5-D8Q SOFT START 3.5 INCH ~ FOR MANUAL
DESCRIPTION	SOFT START 3.5 INCH
SIZE	DWG/PART NO.
A	TB-SS3.5-D8Q
SCALE 1:5	WEIGHT: 24.17 LBS
SHEET 1 OF 1	

© 2013 HALL INDUSTRIES, INC. ALL RIGHTS RESERVED.

HALL INDUSTRIES, INC. PROPRIETARY RIGHTS ARE INCLUDED IN THE INFORMATION DISCLOSED HEREIN. RECIPIENT, BY ACCEPTING THIS DOCUMENT, AGREES THAT NEITHER THIS DOCUMENT NOR THE INFORMATION DISCLOSED HEREIN NOR ANY PART THEREOF SHALL BE REPRODUCED OR TRANSFERRED TO OTHER DOCUMENTS OR USED OR DISCLOSED TO OTHERS FOR MANUFACTURING OR FOR ANY OTHER PURPOSE EXCEPT AS SPECIFICALLY AUTHORIZED IN WRITING BY HALL INDUSTRIES, INC.

NOTES:

1. TAGS MUST BE INSTALLED.

REVISIONS				
REV	DESCRIPTION	DATE	BY	CHK
1	ADD DECAL AND KIT CALLOUT	8/5/2013	BJE	DC

STANDARD EYELET

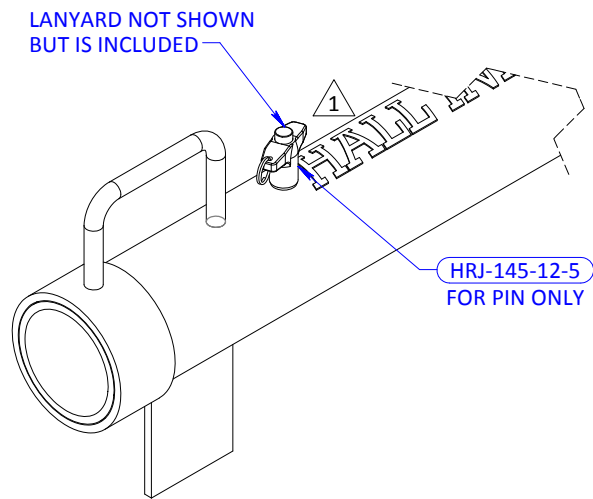
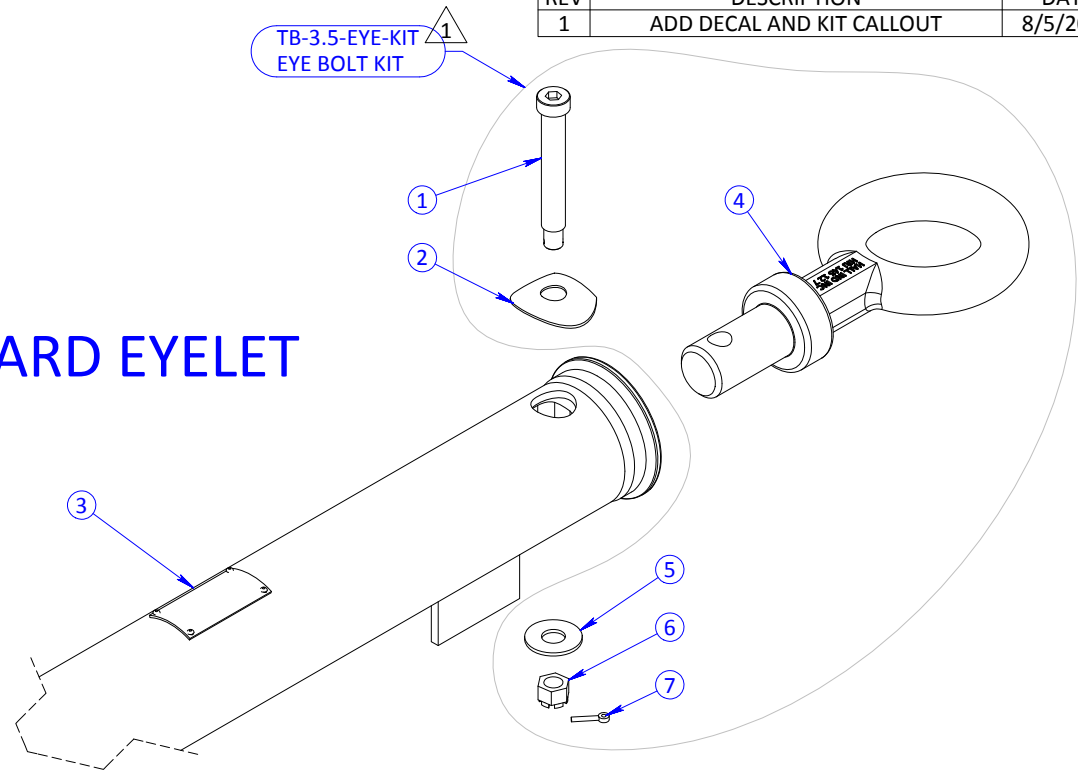

ITEM	QTY	PART NUMBER	DESCRIPTION
1	1	HRJ-145-12-13	SHOULDER BOLT
2	1	HRJ-145-12-14	CURVED WASHER
3	1	HRJ-145-12-1	3.5" TUBE WITH TAG AND DECAL
4	1	HRJ-145-12-7	EYEBOLT
5	1	WH0110000SS0000	WASHER SS
6	1	CN08C0000SS0000	CASTLE NUT SS
7	1	CP4280048SS0000	PIN COTTER

UNLESS OTHERWISE SPECIFIED DIMENSIONS ARE IN INCHES

TOLERANCES

ANGLE	.XX	.XXX
± 0.5°	± .01	± .005
X<12"=± 1/32"	X>12"=±1/16"	

hi 514 Mecklem In Ellwood City, PA 16117
Hall Industries, Inc.

THIRD ANGLE PROJECTION

PROJECT	AV
FILE NAME	HRJ-145-12-1-TE TOWBAR TUBE AND EYE
DESCRIPTION	TOWBAR TUBE AND EYE

CHECK DC	DATE 7/15/2013
DRAWN BJE	DATE 7/15/2013

SIZE A	DWG/PART NO. HRJ-145-12-1-TE	REV 1
SCALE 1:5	WEIGHT: 91.31 LBS	SHEET 1 OF 1

© 2013 HALL INDUSTRIES, INC. ALL RIGHTS RESERVED.

HALL INDUSTRIES, INC. PROPRIETARY RIGHTS ARE INCLUDED IN THE INFORMATION DISCLOSED HEREIN. RECIPIENT, BY ACCEPTING THIS DOCUMENT, AGREES THAT NEITHER THIS DOCUMENT NOR THE INFORMATION DISCLOSED HEREIN NOR ANY PART THEREOF SHALL BE REPRODUCED OR TRANSFERRED TO OTHER DOCUMENTS OR USED OR DISCLOSED TO OTHERS FOR MANUFACTURING OR FOR ANY OTHER PURPOSE EXCEPT AS SPECIFICALLY AUTHORIZED IN WRITING BY HALL INDUSTRIES, INC.

NOTES:

1. TAGS MUST BE INSTALLED.

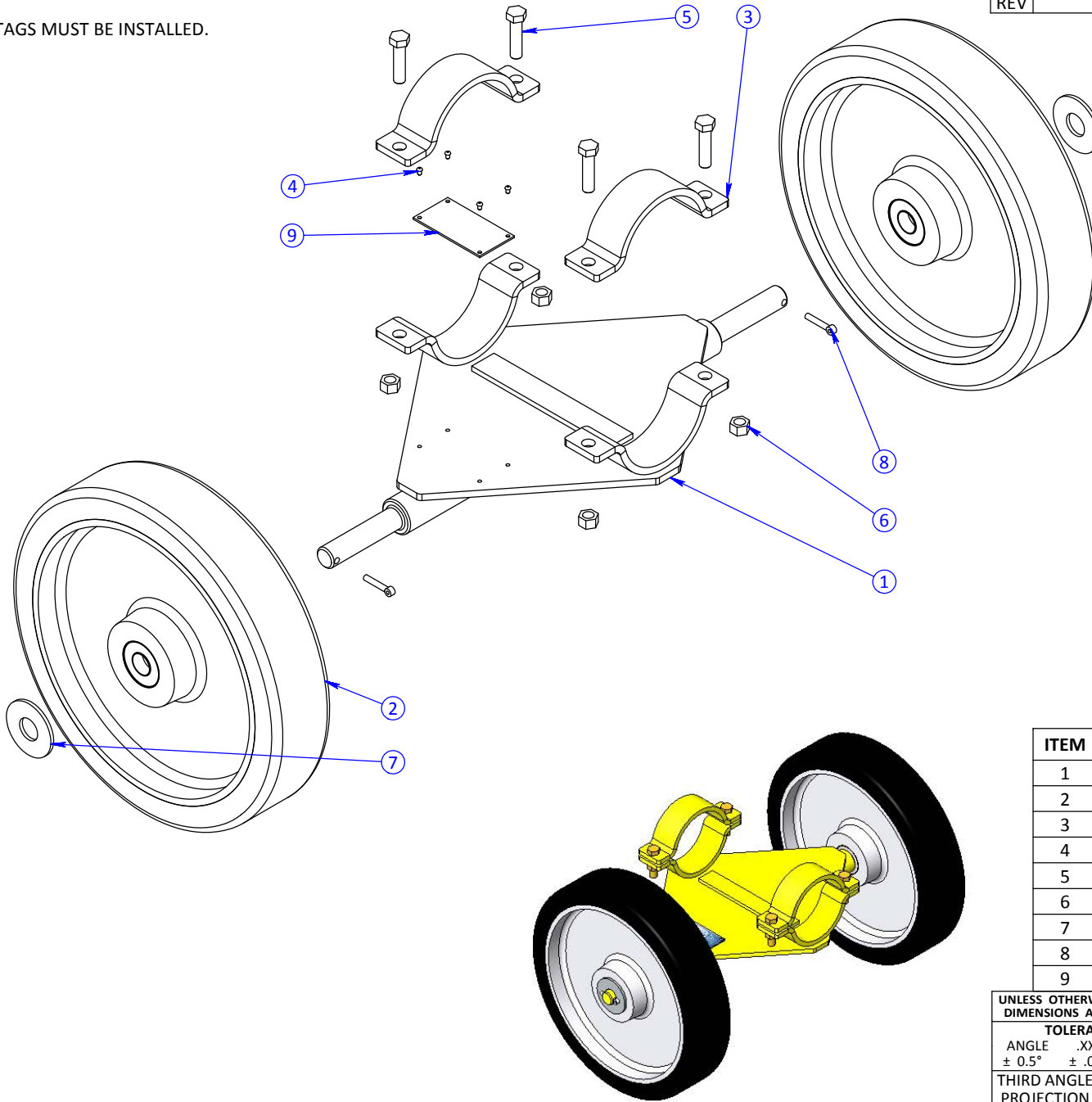

REVISIONS				
REV	DESCRIPTION	DATE	BY	CHK

ITEM	QTY	PART NUMBER	DESCRIPTION
1	1	CRJ-400-1	WHEEL CARRIAGE WELDMENT
2	2	CRJ-WHEEL	WHEEL
3	2	HRJ-145-12-3	CLAMP
4	4	TB-8849-14	DRIVE RIVET
5	4	TB-8898-5	CLAMP BOLT
6	4	TB-8898-6	CLAMP NUT
7	2	TB-8898-8	WASHER
8	2	TB-8898-9	PIN COTTER
9	1	TB-TAG-METAL	HALL INDUSTRIES TAG

UNLESS OTHERWISE SPECIFIED
DIMENSIONS ARE IN INCHES

TOLERANCES

ANGLE	.XX	.XXX
± 0.5°	± .01	± .005

THIRD ANGLE PROJECTION

PROJECT ID: AV1000

CHECK DC	DATE 1/20/2011
DRAWN BJE	DATE 1/20/2011

514 Mecklem In Ellwood City, PA 16117	
Hall Industries, Inc.	
PROJECT	AV
FILE NAME	CRJ-400 FIXED WHEEL CARRIAGE
DESCRIPTION	FIXED WHEEL CARRIAGE
SIZE DWG/PART NO.	A CRJ-400
SCALE 1:5	WEIGHT: 35.23 LBS
SHEET 1 OF 1	

© 2010 HALL INDUSTRIES, INC. ALL RIGHTS RESERVED.

HALL INDUSTRIES, INC. PROPRIETARY RIGHTS ARE INCLUDED IN THE INFORMATION DISCLOSED HEREIN. RECIPIENT, BY ACCEPTING THIS DOCUMENT, AGREES THAT NEITHER THIS DOCUMENT NOR THE INFORMATION DISCLOSED HEREIN NOR ANY PART THEREOF SHALL BE REPRODUCED OR TRANSFERRED TO OTHER DOCUMENTS OR USED OR DISCLOSED TO OTHERS FOR MANUFACTURING OR FOR ANY OTHER PURPOSE EXCEPT AS SPECIFICALLY AUTHORIZED IN WRITING BY HALL INDUSTRIES, INC.

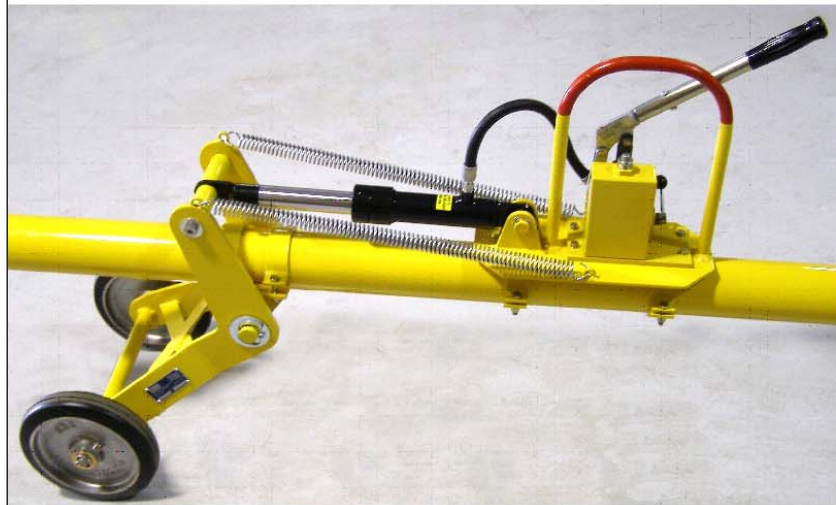
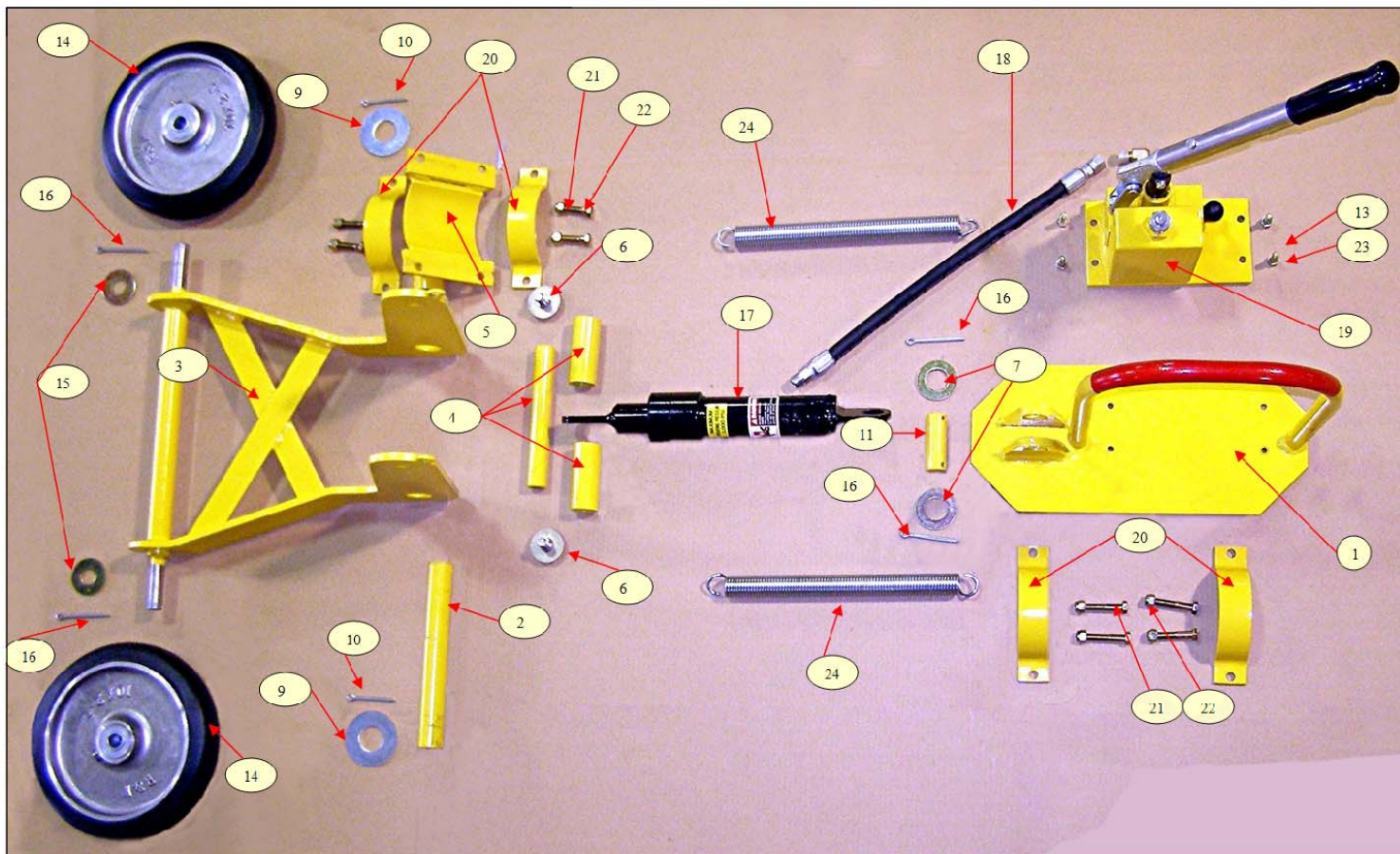

ITEM	QTY	PART NUMBER	DESCRIPTION
1	1	LIFT-1	PUMP MOUNTING BRACKET
2	1	LIFT-4	LOWER PIVOT SHAFT
3	1	LIFT-3	WHEEL ARM WELDMENT
4	1	LIFT-2R	WHEEL ARM PIVOT SHAFT/ W 2 COLLARS
5	1	LIFT-6	WHEEL ARM PIVOT WELDMENT
6	2	LIFT-8	HEX SOCKET SHOULDER BOLT
7	2	TB-8986-9	FLAT WASHER ZP
9	4	LIFT-11	FLAT WASHER SAE ZP
10	2	LIFT-12	COTTER PIN, PIVOT SHAFT
11	1	LIFT-14	CLEVIS PIN
13	4	TB-8714-1	HEX BOLT GR5 ZP
14	2	TB-8898-7	WHEEL 10"
15	2	TB-8898-8	FLAT WASHER USS ZP
16	4	TB-8898-9	COTTER PIN, AXLE
17	1	TB-8714-20	HYD CYLINDER W/QUICK DISC, CPLG
18	1	TB-8714-23	HYDRAULIC HOSE
19	1	TB-8714-24	HYDRAULIC PUMP ASSEMBLY
20	4	HRJ-145-12-3	HANDLE/WHEEL ASSY CLAMP
21	8	TB-8898-5	HEX BOLT GR5 ZP
22	8	TB-8898-6	HEX NUT NYLOCK ZP
23	4	TB-8714-2	LOCK WASHER ZP
24	2	TB-8714-10	EXTENSION SPRING
25	1	TB-TAG-METAL	IDENTIFICATION TAG (NOT SHOWN)
26	4	TB-8849-14	DRIVE RIVET FOR TAG (NOT SHOWN)

UNLESS OTHERWISE SPECIFIED
DIMENSIONS ARE IN INCHES

TOLERANCES

ANGLE	.XX	.XXX
± 0.5°	± .01	± .005

THIRD ANGLE PROJECTION

PROJECT ID AV1000

CHECK DC	DATE 11/20/2010
DRAWN BJE	DATE 11/20/2010

514 Mecklem In Ellwood City, PA 16117
Hall Industries, Inc.

PROJECT	
FILE NAME	REG-LIFT REGIONAL TOWBAR LIFT
DESCRIPTION	REGIONAL TOWBAR LIFT
SIZE DWG/PART NO.	A REG-LIFT
REVISION	0
SCALE 1:1	WEIGHT: 50 LBS
SHEET 1 OF 1	

© 2010 HALL INDUSTRIES, INC. ALL RIGHTS RESERVED.

HALL INDUSTRIES, INC. PROPRIETARY RIGHTS ARE INCLUDED IN THE INFORMATION DISCLOSED HEREIN. RECIPIENT, BY ACCEPTING THIS DOCUMENT, AGREES THAT NEITHER THIS DOCUMENT NOR THE INFORMATION DISCLOSED HEREIN NOR ANY PART THEREOF SHALL BE REPRODUCED OR TRANSFERRED TO OTHER DOCUMENTS OR USED OR DISCLOSED TO OTHERS FOR MANUFACTURING OR FOR ANY OTHER PURPOSE EXCEPT AS SPECIFICALLY AUTHORIZED IN WRITING BY HALL INDUSTRIES, INC.

REVISIONS				
REV	DESCRIPTION	DATE	BY	CHK
1	CLAMP ANGLE	12/17/2012	BJE	VTM

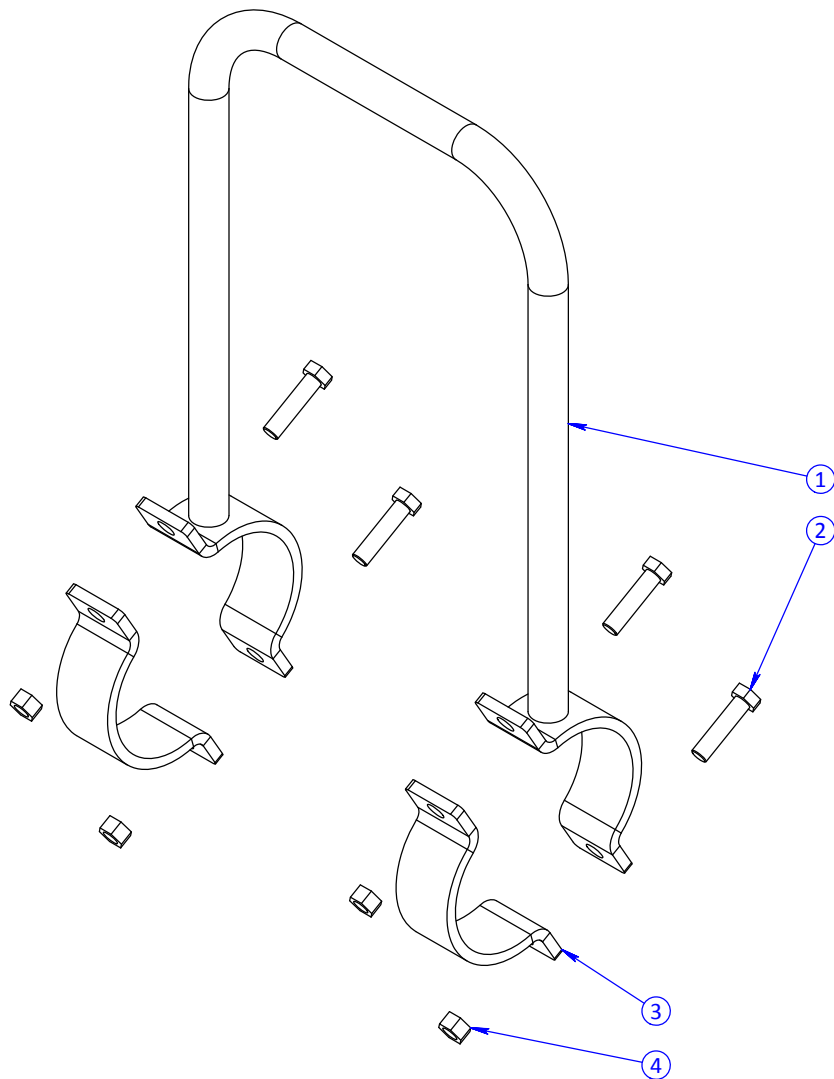

ITEM	QTY	PART NUMBER	DESCRIPTION
1	1	HRJ-145-12-2	HANDLE
2	4	TB-8898-5	CLAMP BOLT
3	2	HRJ-145-12-3	CLAMP
4	4	TB-8898-6	CLAMP NUT

UNLESS OTHERWISE SPECIFIED DIMENSIONS ARE IN INCHES		514 Mecklem In Ellwood City, PA 16117	
TOLERANCES		hi <i>Hall Industries, Inc.</i>	
ANGLE	.XX .XXX	PROJECT	AV
± 0.5°	± .01 ± .005	FILE NAME	HRJ-145-12-2ASY HANDLE ASSEMBLY
THIRD ANGLE PROJECTION		DESCRIPTION	HANDLE ASSEMBLY
PROJECT ID	AV1000	SIZE	DWG/PART NO.
CHECK	DATE	A	HRJ-145-12-2ASY
DC	1/20/2011	REV	1
DRAWN	DATE	SCALE 1:4	WEIGHT: 3.78 LBS
BJE	1/20/2011	SHEET 1 OF 1	

© 2010 HALL INDUSTRIES, INC. ALL RIGHTS RESERVED.
 HALL INDUSTRIES, INC. PROPRIETARY RIGHTS ARE INCLUDED IN THE INFORMATION DISCLOSED HEREIN. RECIPIENT, BY ACCEPTING THIS DOCUMENT, AGREES THAT NEITHER THIS DOCUMENT NOR THE INFORMATION DISCLOSED HEREIN NOR ANY PART THEREOF SHALL BE REPRODUCED OR TRANSFERRED TO OTHER DOCUMENTS OR USED OR DISCLOSED TO OTHERS FOR MANUFACTURING OR FOR ANY OTHER PURPOSE EXCEPT AS SPECIFICALLY AUTHORIZED IN WRITING BY HALL INDUSTRIES, INC.

NOTES:

- USE WHEN FACTORY INSTALLED DRAG PLATES HAVE BEEN WORN DOWN.

REVISIONS				
REV	DESCRIPTION	DATE	BY	CHK

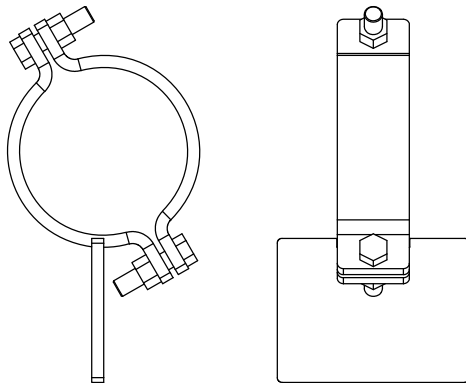
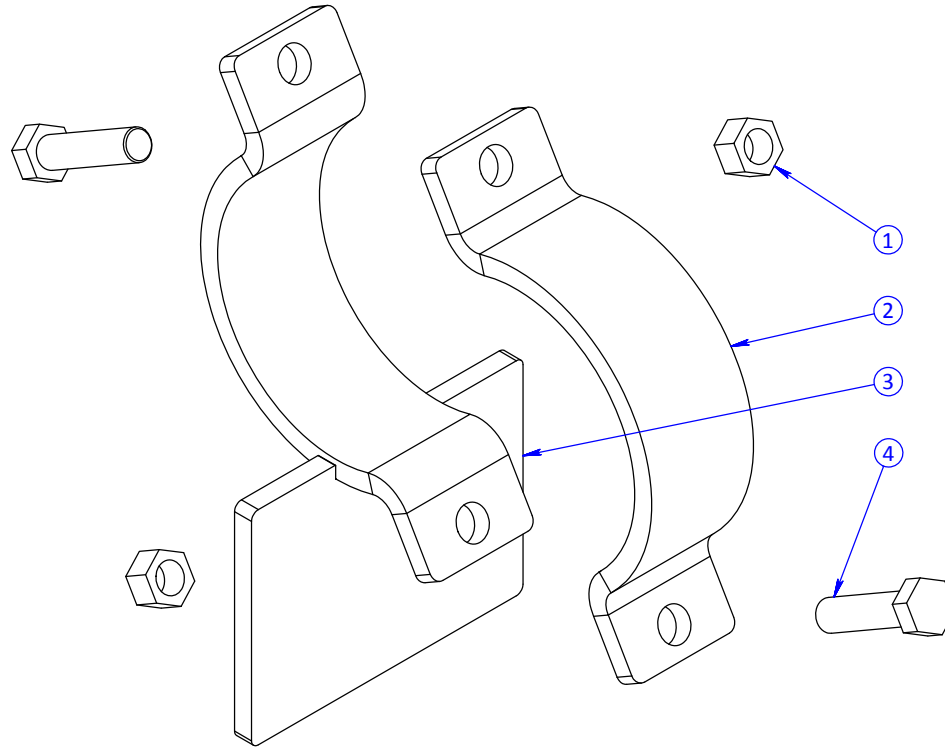

ITEM	QTY	PART NUMBER	DESCRIPTION
1	2	TB-8898-6	CLAMP NUT
2	1	HRJ-145-12-3	CLAMP
3	1	AV1009-3001	DRAG PLATE WELDMENT
4	2	TB-8898-5	CLAMP BOLT

UNLESS OTHERWISE SPECIFIED
DIMENSIONS ARE IN INCHES

TOLERANCES		
ANGLE	.XX	.XXX
± 0.5°	± .01	± .005

THIRD ANGLE PROJECTION

PROJECT ID
AV1009

hi 514 Mecklem In Ellwood City, PA 16117
Hall Industries, Inc.

CHECK BJE	DATE 6/27/2012	SIZE A	DWG/PART NO. AV1009-0002	REV 0
DRAWN BJE	DATE 6/27/2012	SCALE 1:2	WEIGHT: 2.57 LBS	SHEET 1 OF 1

© 2010 HALL INDUSTRIES, INC. ALL RIGHTS RESERVED.

HALL INDUSTRIES, INC. PROPRIETARY RIGHTS ARE INCLUDED IN THE INFORMATION DISCLOSED HEREIN. RECIPIENT, BY ACCEPTING THIS DOCUMENT, AGREES THAT NEITHER THIS DOCUMENT NOR THE INFORMATION DISCLOSED HEREIN NOR ANY PART THEREOF SHALL BE REPRODUCED OR TRANSFERRED TO OTHER DOCUMENTS OR USED OR DISCLOSED TO OTHERS FOR MANUFACTURING OR FOR ANY OTHER PURPOSE EXCEPT AS SPECIFICALLY AUTHORIZED IN WRITING BY HALL INDUSTRIES, INC.



AIRCRAFT TOWBARS - SOFT START

"The GSE Problem Solvers"

BENEFITS

- Decreases shear pin failure resulting in lower more reliable pushback times
- Less shock into the nose gear of the plane



FEATURES

- Replaceable spring elements
- Towbar rollover protection
- Approximately one inch of travel during pushing or pulling (2" overall travel)

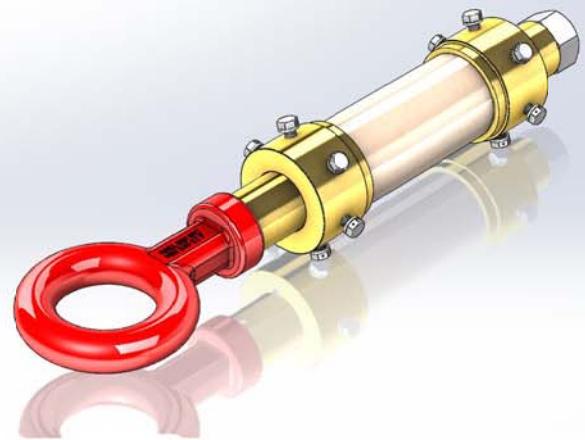

For more information please visit us online at www.halltechservices.com, call us at 724.824.7100, or email us at info@halltechservices.com

Hall Industries Equipment Division ~ AIRLINE ORDERS

FAX#: 724 758-1558 PHONE # : 724 752-2000

ORDER DATE: _____ TAKEN BY: _____ TIME: _____ AIRLINE CODE: _____
 PERSON CALLING: _____ PHONE#: _____ FAX: _____
 E-MAIL ADDRESS: _____ CUSTOMER P.O.# _____
 MASTER CARD# _____
 EXP. DATE: _____ CVC# _____
 SHIP DATE: _____ HOW TO SHIP: UPS: GRD _____ RED _____ OTHER _____
 FED EX: GRD _____ O/N _____ O/N P1 _____ OTHER _____ Acct. # _____
 TRUCKING COMPANY: _____
 HUB : _____ EMPLOYEE # _____
 BILLING ADDRESS: _____ SHIP TO ADDRESS: _____

PART NUMBER:	DESCRIPTION:	QTY:	PRICE:

NOTES: _____

Other Products and Custom Design Services:

Hall Industries provides a number of additional products beyond our towbar line. Some of the custom projects that we have done are shown below. We have our own engineering staff along with machine, fabrication, and GSE maintenance shops. We can design and build your ideas to increase safety, productivity, and profits.



0017-0001 Custom Towbar (Solve a Problem)

<<This project involved designing and manufacturing a custom towbar to be used in the Nuclear Industry. This towbar shipped complete with custom shear pins calibrated to the application.



IA-8980 Preconditioned Air Inlet (PCA) Adapters

<< Our PCA Inlet Adapters are part of our GSE product line. We inventory all of the parts and can ship usually the same day as ordered.>>



0010-0001 Certified Transmission Lifting Bracket (Meet a Demand)

A customer came to us with a lifting problem. They needed a tested and certified lifting bracket to prevent them from getting cited by OSHA. We designed, tested, and fabricated a solution. >>



<<1000-3002 Adapter 8312 to Tronair 1000-0001 Hydro Adapter Assembly>>

Hall Industries offers adapters for nearly every towbar (even competitors) that allow you to use our towbar tubes / heads with your existing equipment.



Besides the products listed above some of the other things that we sell include PCA ducting, Solid PBB tires, and baggage cart tires.

Feel free to contact us about your GSE problems; after all we are "The Problem Solvers".